

SCIENTIFIC REPORTS



OPEN

Simultaneous observation of particle and wave behaviors of entangled photons

Zhong-Xiao Man¹, Yun-Jie Xia¹ & Nguyen Ba An²

Received: 18 October 2016

Accepted: 10 January 2017

Published: 13 February 2017

We theoretically study wave-particle duality of two entangled photons in the spirit of quantum version of delayed-choice experiments using Hadamard gate controlled by the quantum state of an ancilla and show that the two photons may globally exhibit particle-like, wave-like or simultaneously both particle-like and wave-like behavior. We prove that the obtained results cannot be satisfactorily explained by any hidden-variable theory. We also propose an efficient and experimentally feasible scheme without using any ancilla and controlled-gates to directly (i.e., without postselection) observe the two-photon wave-particle superposed state as well as the continuous transition of their behavior between wave-like one and particle-like one.

Wave-particle duality is the most fundamental description of the nature of quantum objects which behave as classical particles in one measurement apparatus, but as classical waves in another measurement apparatus. This is very well demonstrated in the so-called delayed-choice experiments^{1–6}. In the single-photon delayed-choice experiment, a photon is sent into a Mach-Zehnder interferometer (MZI) and split by a balanced beam splitter (BBS) into two traveling paths. After the photon has entered the MZI, one randomly determines whether to recombine the two paths or not by a second BBS. If the second BBS is absent, each detector behind the two paths fires with an equal probability of 1/2, revealing particle property of the photon. By inserting the second BBS, the which-way information of the photon is erased so that the photon exhibits wave property reflected via the dependence of detection probability of each detector upon the phase difference between the two routes. The results of such delayed-choice experiments rule out the possibility of the photon being able to ‘know’ beforehand the specific experimental setting. It also proves that the erasure of the path information is necessary for the photon to form interference between the two paths. In refs 7 and 8, Scully and collaborators proposed the so-called quantum eraser in an entangled atom-photon system. If the path information of the photon (atom) is exposed by the atom (photon), one cannot observe the interference patterns of the photon (atom). In order to recover the interference patterns, one should erase the which-way information^{7,8}. The quantum erasure schemes under various contexts were realized in refs 9–15.

In addition to the single-quantum situation, the interferences in the case of multiphoton entangled states are also extensively studied, which can generally be classified into two types: the first type is to show superresolution effects by manipulating all the photons together in a single interferometer^{16–24}, while the second type is to reveal genuine multiphoton interference by sending each photon into an independent interferometer^{25,26}. Spatial quantum interference of two-mode entangled three-photon state has been observed experimentally in a single interferometer, where the interference fringes are three times denser in comparison to the single-photon state^{19,23}. By contrast, in Ref. 26, three photons that are prepared in Greenberger-Horne-Zeilinger entangled state²⁷ are sent into three independent MZIs, demonstrating three-photon interference that does not originate from two-photon nor single photon interference. To analyze the wave-particle duality for multiphoton states, higher-order duality relations are also proposed^{28,29}.

In a recent development, a quantum version of delayed-choice schemes has been proposed³⁰ where the presence of the second BBS is controlled by a quantum ancilla. The second BBS is removed (inserted) if the ancilla is in the state $|0\rangle$ ($|1\rangle$). Because the ancilla is quantum it can be prepared in a superposed state of $|0\rangle$ and $|1\rangle$ and made entangled with the test system through controlled operation. Then the test system can be projected onto a

¹Shandong Provincial Key Laboratory of Laser Polarization and Information Technology, Department of Physics, Qufu Normal University, Qufu 273165, China. ²Center for Theoretical Physics, Institute of Physics, Vietnam Academy of Science and Technology (VAST), 18 Hoang Quoc Viet, Cau Giay, Hanoi, Vietnam. Correspondence and requests for materials should be addressed to Z.-X.M. (email: zxman@mail.qfnu.edu.cn) or Y.-J.X. (email: yjxia@mail.qfnu.edu.cn) or N.B.A. (email: nban@iop.vast.ac.vn)

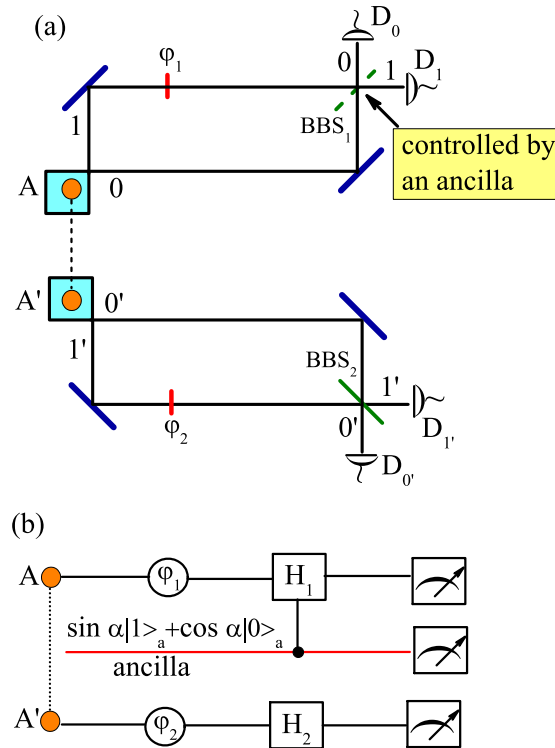

Figure 1. (a) Two entangled photons A and A' are input into two independent interferometers and are transformed to the entanglement of the four paths $0, 1, 0'$ and $1'$, as given in Eq. (1). φ_1 and φ_2 are phase shifters. The existence of BBS_1 is controlled by the state of an ancilla, while BBS_2 is always inserted. (b) The equivalent quantum network. The BBSs correspond to Hadamard gates. The ancilla is prepared in an arbitrary state, $|\psi\rangle_a = \sin\alpha|1\rangle_a + \cos\alpha|0\rangle_a$ and applied to control the operation of H_1 .

superposition of the wave-like and particle-like states depending on the outcome of a suitable measurement of the ancilla. That is, the wave-like and particle-like behaviors of the test system can be observed at the same time in one and the same experimental setting. Through varying the superposition coefficients of $|0\rangle$ and $|1\rangle$ of the ancilla, the test system experiences a continuous morphing between the particle-like and wave-like behaviors. This quantum delayed-choice scheme has been successfully demonstrated in the context of photons^{31–34} and other systems^{35–38}. In the existing implementation of the quantum delayed-choice experiment³⁰, one should employ a quantum ancilla, perform controlling operation on the ancilla and the test system, and make proper measurement on the ancilla.

Although the particle-like and wave-like behaviors of a single photon has been observed simultaneously in one and the same experimental setup, the possibility of such observation regarding multi-photon states remains to be explored. In the present work, we consider the quantum version of delayed-choice experiments designed so that to simultaneously observe both particle and wave behaviors of two entangled photons. It is found that even though each individual photon independently behaves as a particle, their collective properties may not only be particle-like or wave-like but also be both wave-like and particle-like at the same time. We particularly demonstrate the continuous transition between wave and particle behaviors for the entangled photons. We also provide a proof that no hidden-variable (HV) theory can satisfactorily explain the obtained results. Furthermore, we propose an efficient and experimentally feasible scheme which replaces the ancilla, the controlled-Hadamard operation by only a polarizer and a polarization beam splitter (PBS). Our scheme is simple and easily implemented by current technologies because it avoids using controlled-Hadamard gate whose construction and execution are technically difficult. Importantly, in our scheme the wave-particle superposed state of the two photons can be observed directly at the output of the device without any postselection since no measurements at all are required.

Results

Quantum ancilla based scheme. We consider a device consisting of two independent interferometers as shown in Fig. 1(a) to implement the delayed-choice of two-photon interference. At the input sites of the device, two photons A and A' entangled in certain degrees of freedom are sent into the top and the bottom interferometers, respectively, and their states are transformed to the path-entanglement of the interferometers being of the form

$$|\Psi_{in}\rangle_{AA'} = \frac{1}{\sqrt{2}}(|00'\rangle_{AA'} + |11'\rangle_{AA'}), \tag{1}$$

where $|n\rangle$ (with $n = 0, 0', 1, 1'$) represents that there is a photon in the path n . In the path 1 ($1'$), φ_1 (φ_2) denotes the phase shifter introducing a phase difference φ_1 (φ_2) for the paths 0 and 1 ($0'$ and $1'$). At the output sites, the two paths $0'$ and $1'$ of the bottom interferometer are always combined by the BBS₂ (i.e., the bottom interferometer is always closed). As for the paths 0 and 1 of the top interferometer, whether to combine them by the BBS₁ or not (i.e., the top interferometer is either closed or open) is controlled by the state of an ancilla. In Fig. 1(b), we sketch an equivalent quantum network to describe the experiment, where Hadamard gates H_1 and H_2 play the roles of BBS₁ and BBS₂, respectively. Whether the H_1 operates or not for the photon A depends upon the ancilla being in the state $|1\rangle_a$ or $|0\rangle_a$. The photons are detected simultaneously in the form of two-photon coincidence and the collective detection probabilities are employed to characterize the global characters of the two photons as wave-like or particle-like. In the case when the BBS₁ exists (that is, the ancilla is in the state $|1\rangle_a$), the output state of the two photons takes the form

$$|\Psi_w\rangle_{AA'} = \frac{1}{\sqrt{2}} e^{i\frac{\varphi}{2}} \left(\cos \frac{\varphi}{2} |00'\rangle_{AA'} - i \sin \frac{\varphi}{2} |01'\rangle_{AA'} - i \sin \frac{\varphi}{2} |10'\rangle_{AA'} + \cos \frac{\varphi}{2} |11'\rangle_{AA'} \right), \quad (2)$$

with $\varphi = \varphi_1 + \varphi_2$. From Eq. (2), one can see that the collective detection probabilities are related to the phase φ , implying that the two photons exhibit interference. Therefore their global behavior is wave-like and the state (2) is taken for the wave state of the two photons (indicated by a subscript w). By contrast, if the ancilla is in the state $|0\rangle_a$ and the BBS₁ is removed, the output state of the two photons turns out to be

$$|\Psi_p\rangle_{AA'} = \frac{1}{2} \left(|00'\rangle_{AA'} + |01'\rangle_{AA'} + e^{i\varphi} |10'\rangle_{AA'} - e^{i\varphi} |11'\rangle_{AA'} \right). \quad (3)$$

Evidently, all the possible collective detection probabilities of the two photons are equal to 1/4, independent to the phase φ , which implies that the two photons exhibit particle-like behavior. Hence, we take the state (3) to be the particle state of the two photons (indicated by a subscript p).

To simultaneously observe the wave and particle aspects of the two photons, we prepare the ancilla in a superposed state $|\Psi\rangle_a = \sin\alpha|1\rangle_a + \cos\alpha|0\rangle_a$, which formally implies that a quantum beam splitter is applied. In this case, the output state of the two photons are entangled with the ancilla as

$$|\Psi\rangle_{AA'a} = \sin\alpha|\Psi_w\rangle_{AA'}|1\rangle_a + \cos\alpha|\Psi_p\rangle_{AA'}|0\rangle_a, \quad (4)$$

with $|\Psi_w\rangle_{AA'}$ and $|\Psi_p\rangle_{AA'}$ being the wave and particle states of the two photons defined in (2) and (3), respectively. The two-photon state can be post-selected via a measurement on the ancilla. For example, if the ancilla is measured in the basis $\{|+\rangle_a, |-\rangle_a\}$ (with $|\pm\rangle_a = (|0\rangle_a \pm |1\rangle_a)/\sqrt{2}$), the state of the photons will be projected onto a wave-particle superposed state $|\Psi_{wp}\rangle_{AA'} = \cos\alpha|\Psi_p\rangle_{AA'} \pm \sin\alpha|\Psi_w\rangle_{AA'}$ conditioned on the measurement outcomes $|+\rangle_a$ or $|-\rangle_a$ of the ancilla which happens with an equal probability of 1/2.

In the following, we shall prove that no HV theory, in which particle and wave are realistic properties of two entangled photons, can explain this delayed-choice experiment. Following the conditions for a single photon³⁰, a satisfactory HV model should reproduce the quantum mechanical statistics and for a given entangled pair of photons the global behavior of being particle-like or wave-like is intrinsic, i.e., does not change during their lifetime. In the basis $|A\rangle \oplus |A'\rangle \oplus |a\rangle = \{|00'0\rangle, |00'1\rangle, |01'0\rangle, |01'1\rangle, |10'0\rangle, |10'1\rangle, |11'0\rangle, |11'1\rangle\}$ the statistics for the joint measurements of the two photons and the ancilla in the state (4) is

$$P(A, A', a) = \left\{ \frac{1}{4} \cos^2 \alpha, \frac{1}{2} \sin^2 \alpha \cos^2 \left(\frac{\varphi}{2} \right), \frac{1}{4} \cos^2 \alpha, \frac{1}{2} \sin^2 \alpha \sin^2 \left(\frac{\varphi}{2} \right), \frac{1}{4} \cos^2 \alpha, \frac{1}{2} \sin^2 \alpha \sin^2 \left(\frac{\varphi}{2} \right), \frac{1}{4} \cos^2 \alpha, \frac{1}{2} \sin^2 \alpha \cos^2 \left(\frac{\varphi}{2} \right) \right\}. \quad (5)$$

We shall reveal a contradiction of the HV model between the reproduction of the statistics $P(A, A', a)$ and keeping consistent behaviors of wave and particle during the experimental process.

Proof. Suppose there is an extra degree of freedom λ , which is the hidden variable and determines particle-like ($\lambda = p$) or wave-like ($\lambda = w$) behavior of the two entangled photons. According to the standard conditions for probability distributions, we have

$$\begin{aligned} P(A, A', a) &= \sum_{\lambda} P(A, A', a, \lambda) \\ &= \sum_{\lambda} P(A, A'|a, \lambda) P(a|\lambda) P(\lambda), \end{aligned} \quad (6)$$

where $P(A, A'|a, \lambda)$ is the collective probability of detecting A and A' conditioned on the given values of a and λ , $P(a|\lambda)$ is the probability of a (being 0 or 1) conditioned on the value of λ , and $P(\lambda)$ is the probability of the source to emit the wave-like or particle-like photons. If the source emits two entangled photons with the wave-like property and meanwhile the BBS₁ is inserted ($a = 1$), then the collective statistics is consistent with our previous derivation of the wave state of the two photons, namely,

$$P(A, A'|a = 1, \lambda = w) = \left\{ \frac{1}{2} \cos^2\left(\frac{\varphi}{2}\right), \frac{1}{2} \sin^2\left(\frac{\varphi}{2}\right), \frac{1}{2} \sin^2\left(\frac{\varphi}{2}\right), \frac{1}{2} \cos^2\left(\frac{\varphi}{2}\right) \right\}. \quad (7)$$

Similarly, if the emitted entangled photons possess particle-like property and meanwhile BBS₁ is absent ($a = 0$), then the collective statistics read

$$P(A, A'|a = 0, \lambda = p) = \left\{ \frac{1}{4}, \frac{1}{4}, \frac{1}{4}, \frac{1}{4} \right\}. \quad (8)$$

In case the wave-like photons ($\lambda = w$) are injected into the device in the absence of BBS₁ ($a = 0$), whereas the particle-like photons ($\lambda = p$) are input in the presence of BBS₁ ($a = 1$), the collective statistics are expressed respectively as

$$P(A, A'|a = 0, \lambda = w) = \{x_1, y_1, z_1, 1 - x_1 - y_1 - z_1\}, \quad (9)$$

and

$$P(A, A'|a = 1, \lambda = p) = \{x_2, y_2, z_2, 1 - x_2 - y_2 - z_2\}, \quad (10)$$

in which the distributions x_i, y_i, z_i ($i = 1, 2$) are unknown. We assume that the source randomly emits particle-like or wave-like entangled photons with probability f or $1 - f$, respectively, namely, $P(\lambda) = \{f, 1 - f\}$. The conditional probability distributions of the ancilla a and the hidden variable λ are supposed as

$$P(a|\lambda = w) = \{s, 1 - s\}, \quad P(a|\lambda = p) = \{t, 1 - t\}. \quad (11)$$

From Eqs (5) and (6) with the constraints (7) and (8) we obtain

$$x_1 s(1 - f) + \frac{1}{4} t f = \frac{1}{4} \cos^2 \alpha, \quad (12)$$

$$\frac{1}{2} \cos^2\left(\frac{\varphi}{2}\right)(1 - s)(1 - f) + x_2(1 - t)f = \frac{1}{2} \sin^2 \alpha \cos^2\left(\frac{\varphi}{2}\right), \quad (13)$$

$$y_1 s(1 - f) + \frac{1}{4} t f = \frac{1}{4} \cos^2 \alpha, \quad (14)$$

$$\frac{1}{2} \sin^2\left(\frac{\varphi}{2}\right)(1 - s)(1 - f) + y_2(1 - t)f = \frac{1}{2} \sin^2 \alpha \sin^2\left(\frac{\varphi}{2}\right), \quad (15)$$

$$z_1 s(1 - f) + \frac{1}{4} t f = \frac{1}{4} \cos^2 \alpha, \quad (16)$$

$$\frac{1}{2} \sin^2\left(\frac{\varphi}{2}\right)(1 - s)(1 - f) + z_2(1 - t)f = \frac{1}{2} \sin^2 \alpha \sin^2\left(\frac{\varphi}{2}\right), \quad (17)$$

$$(1 - x_1 - y_1 - z_1)s(1 - f) + \frac{1}{4} t f = \frac{1}{4} \cos^2 \alpha \quad (18)$$

$$\frac{1}{2} \cos^2\left(\frac{\varphi}{2}\right)(1 - s)(1 - f) + (1 - t)f(1 - x_2 - y_2 - z_2) = \frac{1}{2} \sin^2 \alpha \cos^2\left(\frac{\varphi}{2}\right). \quad (19)$$

The above Eqs (12)–(19) contain three types of solutions. The first type is $x_1 = y_1 = z_1 = 1/4$, which implies that wave-like photons in the device without BBS₁ have particle-like statistics: $P(A, A'|a = 0, \lambda = w) = \{1/4, 1/4, 1/4, 1/4\}$. The second type solution is $x_2 = \cos^2(\varphi/2)/2$, $y_2 = \sin^2(\varphi/2)/2$, $z_2 = \sin^2(\varphi/2)/2$ which indicates that particle-like photons in the device with BBS₁ have wave-like statistics: $P(A, A'|a = 1, \lambda = p) = \{\cos^2(\varphi/2)/2, \sin^2(\varphi/2)/2, \sin^2(\varphi/2)/2, \cos^2(\varphi/2)/2\}$. These solutions are not acceptable, as the photons show incompatible behaviors. The last type solution is $s = 0$, $t = 1$ and $f = \cos^2 \alpha$, which means that the randomly emitted particle-like and wave-like photons have a distribution $P(\lambda) = \{\cos^2 \alpha, \sin^2 \alpha\}$ which is identical to the probability distribution of the ancilla $P(a) = \{\cos^2 \alpha, \sin^2 \alpha\}$. Moreover, whenever the source emits particle-like photons the value of a is found to be 0, that is $P(a|\lambda = p) = \{1, 0\}$ and the BBS₁ is absent. On the other hand, when it emits wave-like photons the value of a is measured as 1, that is $P(a|\lambda = w) = \{0, 1\}$, so the BBS₁ is inserted. The hidden variable λ and the ancilla a are perfectly correlated. Although the probability distribution $P(\lambda)$ is identical to $P(a)$, namely, the hidden variable completely determines the values of a , the probability distribution $P(a)$, given by the parameter α of the ancilla's state, is subjectively determined by the experimenter's preparation. As was verified in ref. 30, if the hidden variable λ completely determines a , then λ itself cannot be determined by the setting α in preparing a .

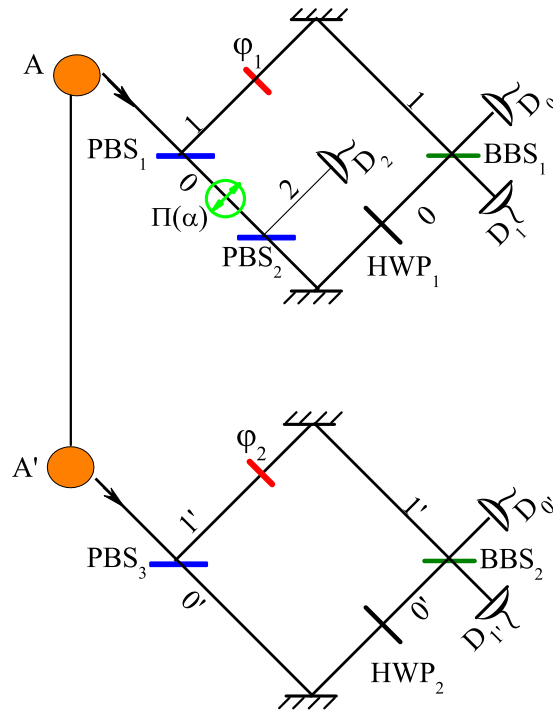

Figure 2. An experimental scheme for demonstrating both wave and particle behaviors of two photons A and A' initially being in polarization-entanglement. After the PBS_1 and PBS_3 , the polarization-entanglement of the photons is transformed to path-entanglement. φ_1 and φ_2 are the phase shifters. $\Pi(\alpha)$ is the polarizer inserted in path 0 where an additional PBS, i.e., PBS_2 , and the corresponding detectors D_2 are also placed. HWP_1 and HWP_2 denote the half-wave plates. The paths 0, 1 and $0'$, $1'$ are combined by BBS_1 and BBS_2 , respectively.

Therefore, we conclude that the HV model that could reproduce the statistics $P(A, A', a)$ cannot keep consistent behaviors of wave and particle of the entangled photons.

Proposed experimentally feasible scheme. In this section, we propose an experimentally feasible scheme to implement the simultaneous observation of both aspects of wave and particle of two entangled photons. Our scheme is shown in Fig. 2, where two photons A and A' are prepared initially in the polarization entanglement state as

$$|\Psi_0\rangle_{AA'} = \frac{1}{\sqrt{2}}(|HH\rangle_{AA'} + |VV\rangle_{AA'}), \quad (20)$$

where $|H\rangle$ and $|V\rangle$ represent the photon being in the horizontal and vertical polarizations, respectively. In order to transform the polarization entanglement to the path entanglement, two PBSs, PBS_1 and PBS_3 , are placed at the input sites of the device. Since the PBS transmits (reflects) the photon with horizontal (vertical) polarization, after PBS_1 and PBS_3 , the state (20) is transformed to

$$|\Psi\rangle_{AA'} = \frac{1}{\sqrt{2}}(|0_H 0'_H\rangle_{AA'} + |1_V 1'_V\rangle_{AA'}), \quad (21)$$

where $|n_{H(V)}\rangle$ means that there is a horizontally (vertically) polarized photon in the path $n = \{0, 0', 1, 1'\}$. In paths 1 and $1'$, we use the phase shifters denoted by φ_1 and φ_2 to vary the phase differences of the two photon paths. In the path 0, we use a polarizer $\Pi(\alpha)$ to transform the photon state $|0_H\rangle$ to $\sin\alpha|0_H\rangle + \cos\alpha|0_V\rangle$. After the polarizer, another PBS_2 is placed in the path 0. Therefore, the photon in the path 0 with the vertical polarization is reflected by PBS_2 and detected at the detector D_2 , otherwise it is transmitted through the PBS_2 , which means that there is nothing in this path. To ensure the possible interference, we use two half-wave plates (HWPs), HWP_1 and HWP_2 , to rotate the horizontal polarizations of the photons to the vertical polarizations. In the end of the device, the two photon paths 0 and 1 ($0'$ and $1'$) are combined by BBS_1 (BBS_2).

Remarkably, instead of using a real quantum ancilla to control the existence of BBS_1 , in our scheme the polarizer $\Pi(\alpha)$ and PBS_2 play the role of controller. If we set $\alpha = 0$, the photon in path 0 is vertically polarized and the PBS_2 is equivalent to a mirror. In this case, the total device is equivalent to the scheme described in Fig. 1 with the top interferometer being open, i.e., the BBS_1 being removed, so that the two photons exhibit particle-like behaviors. In contrast, if we set $\alpha = \pi/2$, the photon in path 0 is horizontally polarized and the PBS_2 is equivalent to nothing. The total device is just the scheme described in Fig. 1 with two closed interferometers so that the two photons are wave-like. Of interest is the setting $0 < \alpha < \pi/2$, under which the PBS_2 is semitransparent, being

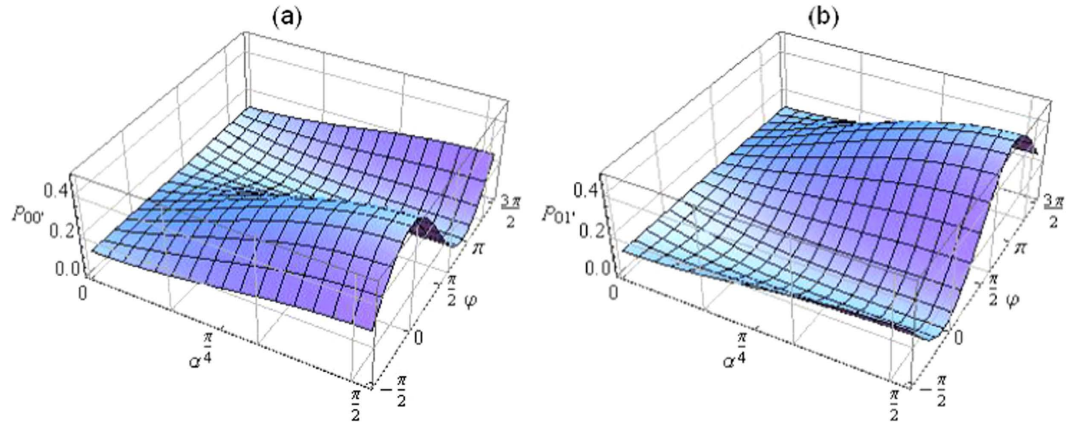

Figure 3. The collective detection probabilities (a) $P_{00'}=P_{11'}$ and (b) $P_{01'}=P_{10'}$, Eqs (23) and (24), of the two photons as functions of α and φ . The morphing between the particle-like ($\alpha=0$) and the wave-like ($\alpha=\pi/2$) behavior of the two photons can be seen by changing α from 0 to $\pi/2$ or vice versa.

equivalent to a superposition of existence and absence of the BBS_1 for the scheme described in Fig. 1. Therefore, with $0 < \alpha < \pi/2$ we obtain a superposed state of wave and particle of the two photons.

Our calculations yield the output state of the two photons as

$$\begin{aligned}
 |\Phi\rangle_{AA'} = & -\frac{1}{2\sqrt{2}}\left[(\sin\alpha + e^{i\varphi})(|00'\rangle_{AA'} + |11'\rangle_{AA'}) + (\sin\alpha - e^{i\varphi})\right. \\
 & \left.(|01'\rangle_{AA'} + |10'\rangle_{AA'})\right] \\
 & + \frac{i}{2}\cos\alpha(|20'\rangle_{AA'} + |21'\rangle_{AA'}), \tag{22}
 \end{aligned}$$

in which we have omitted the polarization indices and taken into account the action of the mirror as $|n\rangle \rightarrow i|n\rangle$. As can be derived from Eq. (22), the collective detection probabilities of the two photons are

$$P_{00'} = P_{11'} = \frac{1}{8} + \frac{1}{4}\sin\alpha\cos\varphi + \frac{1}{8}\sin^2\alpha, \tag{23}$$

$$P_{01'} = P_{10'} = \frac{1}{8} - \frac{1}{4}\sin\alpha\cos\varphi + \frac{1}{8}\sin^2\alpha, \tag{24}$$

$$P_{20'} = \frac{1}{2}\cos^2\alpha. \tag{25}$$

By setting $\alpha=0$ in Eqs (23)–(25), we get $P_{00'}=P_{11'}=P_{01'}=P_{10'}=1/8$ and $P_{20'}=1/2$, all of which are independent to φ reflecting the particle-like character of the two entangled photons. By setting $\alpha=\pi/2$, we have nonzero collective probabilities $P_{00'}=P_{11'}=\cos^2(\varphi/2)/2$ and $P_{01'}=P_{10'}=\sin^2(\varphi/2)/2$, which are related to φ reflecting the wave-like character of the two entangled photons. For $0 < \alpha < \pi/2$, the two photons exhibit at the same time both the wave-like and particle-like characters, which is most evident when D_2 does not respond, in which case the state (22) collapses into

$$|\Phi_{wp}\rangle_{AA'} = \frac{1}{\sqrt{1+\sin^2\alpha}}\left[\sqrt{2}\sin\alpha|\Psi_w\rangle_{AA'} + (1-\sin\alpha)|\Psi_p'\rangle_{AA'}\right], \tag{26}$$

where $|\Psi_w\rangle_{AA'}$ is defined in (2) as a wave state and $|\Psi_p'\rangle_{AA'} = \frac{1}{2}e^{i\varphi}(|00'\rangle_{AA'} + |11'\rangle_{AA'} - |01'\rangle_{AA'} - |10'\rangle_{AA'})$ is a particle state (i.e., the detection probabilities are φ -independent) as that defined in (3) up to a unitary operation $U_{AA'} = e^{i\varphi}|00'\rangle_{AA'}\langle 00'| - e^{i\varphi}|01'\rangle_{AA'}\langle 01'| - |10'\rangle_{AA'}\langle 10'| - |11'\rangle_{AA'}\langle 11'|$ (i.e., $|\Psi_p'\rangle_{AA'} = U_{AA'}|\Psi_p\rangle_{AA'}$). Therefore, the state (26) is a superposition of the wave-like state and the particle-like state (indicated by a subscript wp). The dependences of $P_{00'}=P_{11'}$ and $P_{01'}=P_{10'}$ on α and φ are displayed in Fig. 3, reflecting clearly the particle-like (wave-like) behavior at $\alpha=0$ ($\alpha=\pi/2$) and a continuous transition between these two extreme cases as α gradually varies from 0 to $\pi/2$ or vice versa.

In the following, we analyze how possible experimental imperfections in the state generation and detection processes affect our results. Due to practical device/operation imperfections the desired maximally entangled state $|\Psi_0\rangle_{AA'}$ may not be generated. Instead, a non-maximally entangled state $|\mu_0\rangle_{AA'} = \cos\theta|HH\rangle_{AA'} + \sin\theta|VV\rangle_{AA'}$ or, more generally, a classical mixture as a Werner-like state³⁹

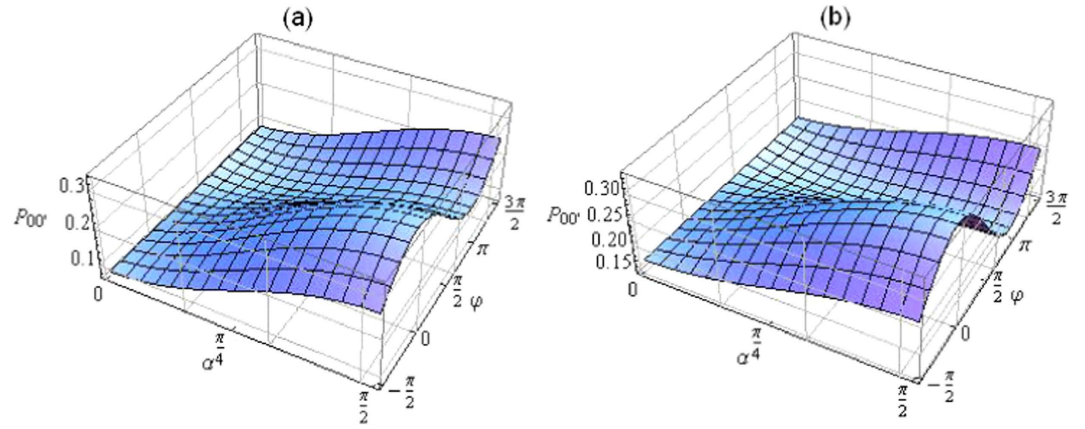

Figure 4. The collective detection probabilities $P_{00'} = P_{11'}$ of the two photons as functions of α and φ for the Werner-like input state (27) for $q = 1/2$ and for (a) $\theta = \pi/8$ and (b) $\theta = 3\pi/8$. The morphing between the particle-like ($\alpha = 0$) and the wave-like ($\alpha = \pi/2$) behavior of the two photons can still be seen by changing α from 0 to $\pi/2$ or vice versa.

$$\rho_{AA'}^{in} = q|\mu_0\rangle_{AA'}\langle\mu_0| + (1 - q)I_A \otimes I_{A'}, \quad (27)$$

with $0 \leq q \leq 1$ and $I_{A(A')} = \frac{1}{2}[|H\rangle_{A(A')}\langle H| + |V\rangle_{A(A')}\langle V|]$ is obtained. In this case, the output state of the two photons can be derived as

$$\rho_{AA'}^{out} = q|\nu\rangle_{AA'}\langle\nu| + (1 - q)\rho_A \otimes \rho_{A'} \quad (28)$$

where

$$\begin{aligned} |\nu\rangle_{AA'} = & -\frac{1}{2}(\cos\theta \sin\alpha + \sin\theta e^{i\varphi})(|00'\rangle_{AA'} + |11'\rangle_{AA'}) + \frac{1}{2}(\sin\theta e^{i\varphi} - \cos\theta \sin\alpha) \\ & \times (|01'\rangle_{AA'} + |10'\rangle_{AA'}) + \frac{i}{\sqrt{2}}\cos\theta \cos\alpha (|20'\rangle_{AA'} + |21'\rangle_{AA'}), \end{aligned} \quad (29)$$

$$\begin{aligned} \rho_A = & \frac{1}{4}(1 + \sin^2\alpha)(|0\rangle_A\langle 0| + |1\rangle_A\langle 1|) - \frac{1}{4}\cos^2\alpha(|0\rangle_A\langle 1| - |1\rangle_A\langle 0|) + \frac{1}{2\sqrt{2}}\sin\alpha \\ & \times \cos\alpha(|0\rangle_A\langle 2| + |2\rangle_A\langle 0| + |1\rangle_A\langle 2| + |2\rangle_A\langle 1|) + \frac{1}{2}\cos^2\alpha|2\rangle_A\langle 2|, \end{aligned} \quad (30)$$

and

$$\rho_{A'} = \frac{1}{2}(|0'\rangle_{A'}\langle 0'| + |1'\rangle_{A'}\langle 1'|). \quad (31)$$

Clearly, the above state (28) is reduced to Eq. (22) when $q = 1$ and $\theta = \pi/4$ corresponding to the maximally entangled input state $|\Psi_0\rangle_{AA'}$. Note that for $q = 0$ the input state of the two photons is separable (here each photon is in a maximally mixed state) and no interference patterns appear at all (ρ_A and $\rho_{A'}$ are both independent of φ), indicating the necessity of entanglement in the input state for observing the photons' wave-like feature. The dependences of $P_{00'} = P_{11'}$ on α and φ for $0 < q < 1$ and $\theta \neq \pi/4$, are displayed in Fig. 4(a) and (b) for $q = 1/2$, while $\theta = \pi/8$ and $\theta = 3\pi/8$, respectively. Apart from the quantitative differences with respect to the imperfection-free situation (i.e., $q = 1$ and $\theta = \pi/4$), the figures still qualitatively demonstrate the particle-like (wave-like) behavior at $\alpha = 0$ ($\alpha = \pi/2$) and a continuous transition between these two extreme cases as α gradually varies from 0 to $\pi/2$ or vice versa.

Next, we consider imperfection in the detection process. Namely, we assume that the photon detectors are not ideal, i.e., their efficiencies are smaller than 1. Let $\eta_m < 1$ ($\eta_{m'} < 1$) with $m = 0, 1$ be the efficiency of the imperfect detector D_m ($D_{m'}$). Such a detector could be modeled by a perfect detector to be placed behind a lossless unbalanced beam-splitter with transmittivity $T_m = \eta_m$ ($T_{m'} = \eta_{m'}$) at which the photon of interest is superimposed with the vacuum. The transmitted part with probability η_m ($\eta_{m'}$) propagates towards the perfect detector, while the reflected part with probability $1 - \eta_m$ ($1 - \eta_{m'}$) is assumed to be absorbed by the environment. Then the collective detection probabilities $P_{mm'}$ resulted from the imperfect detectors are proportional to $\sqrt{\eta_m \eta_{m'}}$. This though reduces the detection probabilities, but retains their dependences on α and φ unchanged for given detector efficiencies. In other words, one can still observe the continuous transition between the particle-like and wave-like behaviors of the two photons using inefficient detectors.

Discussion

Following the successful investigation, both theoretical and experimental, of the quantum version of delayed-choice schemes for a single photon, we extend the idea to the case of two entangled photons. By sending each photon of the photon entangled pair to an interferometer and controlling the operation of Hadamard gate on one photon by an ancilla prepared in a quantum superposed state followed by measuring the ancilla in a suitable basis we can reveal the global properties of the two photons as particle-like, wave-like or both particle- and wave-like at the same time, though the independent behavior of an individual photon is always particle-like. By varying the ancilla state parameter we can also observe continuous transition from particle-like behavior to wave-like one and vice versa. We have proved that the obtained results cannot be a consequence of any HV theory which would yield inconsistency in the photons' behaviors. An important contribution of the present work is proposal of a new scheme for observing two-photon wave-particle duality. Our scheme is efficient and experimentally feasible because it gets rid of the employment of ancilla, the controlling operation on the test system by the ancilla as well as the postselection conditioned on the necessary measurement on the ancilla. Therefore, in our scheme we can directly (i.e., without any postselection) observe the desired wave-particle superposed state of two photons as well as the continuous transition between the particle and wave behaviors of the two photons. Our scheme could be realized in the lab using current technologies.

References

1. Wheeler, J. A. *Quantum Theory and Measurement* (ed. Wheeler, J. A. & Zurek, W. H.) 182–213 (Princeton Univ. Press, Princeton, NJ, 1984).
2. Ma, X. S., Kofler, J. & Zeilinger, A. Delayed-choice gedanken experiments and their realizations. *Rev. Mod. Phys.* **88**, 015005 (2016).
3. Hellmuth, T., Walther, H., Zajonc, A. & Schleich, W. Delayed-choice experiments in quantum interference. *Phys. Rev. A* **35**, 2532 (1987).
4. Lawson-Daku, B. J. *et al.* Delayed choices in atom Stern-Gerlach interferometry. *Phys. Rev. A* **54**, 5042 (1996).
5. Jacques, V. *et al.* Experimental realization of Wheeler's delayed-choice gedanken experiment. *Science* **315**, 966–968 (2007).
6. Manning, A. G., Khakimov, R. I., Dall, R. G. & Truscott, A. G. Wheeler's delayed-choice gedanken experiment with a single atom. *Nature Phys.* **11**, 539–542 (2015).
7. Scully, M. O. & Drühl, K. Quantum eraser: a proposed photon correlation experiment concerning observation and delayed choice in quantum mechanics. *Phys. Rev. A* **25**, 2208 (1982).
8. Scully, M. O., Englert, B. G. & Walther, H. Quantum optical tests of complementarity. *Nature* **351**, 111–116 (1991).
9. Eichmann, U. *et al.* Young's interference experiment with light scattered from two atoms. *Phys. Rev. Lett.* **70**, 2359 (1993).
10. Dürr, S., Nonn, T. & Rempe, G. Origin of quantum-mechanical complementarity probed by a which-way experiment in an atom interferometer. *Nature* **395**, 33–37 (1998).
11. Gerry, C. C. Complementarity and quantum erasure with dispersive atom-field interactions. *Phys. Rev. A* **53**, 1179 (1996).
12. Herzog, T. J., Kwiat, P. G., Weinfurter, H. & Zeilinger, A. Complementarity and the quantum eraser. *Phys. Rev. Lett.* **75**, 3034 (1995).
13. Kim, Y.-H., Yu, R., Kulik, S. P., Shih, Y. & Scully, M. O. Delayed choice quantum eraser. *Phys. Rev. Lett.* **84**, 1 (2000).
14. Ma, X. S. *et al.* Quantum erasure with causally disconnected choice. *Proc. Natl. Acad. Sci. USA* **110**, 1221 (2013).
15. Liu, K. *et al.* A two-fold quantum delayed-choice experiment in a superconducting circuit. *arXiv:1608.04908v1 [quant-ph]* (2016).
16. Pan, J. W. *et al.* Multiphoton entanglement and interferometry. *Rev. Mod. Phys.* **84**, 777 (2012).
17. Barnett, S. M., Imoto, N. & Huttner, B. Photonic de Broglie wave interferometers. *J. Mod. Opt.* **45**, 2217 (1998).
18. Walther, P. *et al.* De Broglie wavelength of a non-local four-photon state. *Nature* **429**, 158–161 (2004).
19. Mitchell, M. W., Lundeen, J. S. & Steinberg, A. M. Super-resolving phase measurements with a multiphoton entangled state. *Nature* **429**, 161–164 (2004).
20. Kim, H., Lee, S. M. & Moon, H. S. Two-photon interference of temporally separated photons. *Sci. Rep.* **6**, 34805 (2016).
21. Kim, H., Lee, S. M. & Moon, H. S. Generalized quantum interference of correlated photon pairs. *Sci. Rep.* **5**, 9931 (2015).
22. Jin, X.-M. *et al.* Sequential path entanglement for quantum metrology. *Sci. Rep.* **3**, 1779 (2013).
23. Kim, Y. S. *et al.* Observation of Young's double-slit interference with the three-photon N00N state. *Opt. Express* **19**, 24957–24966 (2011).
24. Kwon, O., Ra, Y. S. & Kim, Y. H. Observing photonic de Broglie waves without the maximally-path-entangled $|N, 0\rangle + |0, N\rangle$ state. *Phys. Rev. A* **81**, 063801 (2010).
25. Franson, J. D. Bell inequality for position and time. *Phys. Rev. Lett.* **62**, 2205 (1989).
26. Agne, S. *et al.* Observation of genuine three-photon interference. *arXiv:1609.07508v1 [quant-ph]* (2016).
27. Greenberger, D. M., Horne, M. A., Shimony, A. & Zeilinger, A. Bell's theorem without inequalities. *Am. J. Phys.* **58**, 1131 (1990).
28. Huang, J., Liu, H. Y., Gao, J. R., Zubairy, M. S. & Zhu, S. Y. Experimental test of the first- and second-order duality relations for the two-photon states. *Phys. Rev. A* **88**, 013828 (2013).
29. Huang, J. H., Wölk, S., Zhu, S. Y. & Zubairy, M. S. Higher-order wave-particle duality. *Phys. Rev. A* **87**, 022107 (2013).
30. Ionicioiu, R. & Terno, D. R. Proposal for a quantum delayed-choice experiment. *Phys. Rev. Lett.* **107**, 230406 (2011).
31. Tang, J. S. *et al.* Realization of quantum Wheeler's delayed choice experiment. *Nature Photon.* **6**, 600–604 (2012).
32. Peruzzo, A., Shadbolt, P., Brunner, N., Popescu, S. & O'Brien, J. L. A quantum delayed choice experiment. *Science* **338**, 634–637 (2012).
33. Kaiser, F., Coudreau, T., Milman, P., Ostrowsky, D. B. & Tanzilli, S. Entanglement-enabled delayed choice experiment. *Science* **338**, 637–640 (2012).
34. Yan, H. *et al.* Experimental observation of simultaneous wave and particle behavior in a narrowband single-photon wave packet. *Phys. Rev. A* **91**, 042132 (2015).
35. Roy, S., Shukla, A. & Mahesh, T. S. NMR implementation of a quantum delayed-choice experiment. *Phys. Rev. A* **85**, 022109 (2012).
36. Auccaise, R. *et al.* Experimental analysis of the quantum complementarity principle. *Phys. Rev. A* **85**, 032121 (2012).
37. Zheng, S. B. *et al.* Quantum delayed-choice experiment with a beam splitter in a quantum superposition. *Phys. Rev. Lett.* **115**, 260403 (2015).
38. Xin, T., Li, H., Wang, B. X. & Long, G. L. Realization of an entanglement-assisted quantum delayed-choice experiment. *Phys. Rev. A* **92**, 022126 (2015).
39. Werner, R. F. Quantum states with Einstein-Podolsky-Rosen correlations admitting a hidden-variable model. *Phys. Rev. A* **40**, 4277 (1989).

Acknowledgements

In this work Z.X.M. and Y.J.X. are supported by National Natural Science Foundation of China under Grant No. 11574178 and No. 61675115, Shandong Provincial Natural Science Foundation (China) under Grant No. ZR2016JL005, the Specialized Research Fund for the Doctoral Program of Higher Education under Grant No.

20133705110001, while N.B.A. is funded by the Vietnam National Foundation for Science and Technology Development (NAFOSTED) under project no. 103.01-2014.02.

Author Contributions

N.B.A. and Z.X.M. conceived the initial idea. Z.X.M. performed the calculations with help from N.B.A. All the authors discussed the results and contributed to the preparation of the manuscript.

Additional Information

Competing financial interests: The authors declare no competing financial interests.

How to cite this article: Man, Z.-X. *et al.* Simultaneous observation of particle and wave behaviors of entangled photons. *Sci. Rep.* 7, 42539; doi: 10.1038/srep42539 (2017).

Publisher's note: Springer Nature remains neutral with regard to jurisdictional claims in published maps and institutional affiliations.



This work is licensed under a Creative Commons Attribution 4.0 International License. The images or other third party material in this article are included in the article's Creative Commons license, unless indicated otherwise in the credit line; if the material is not included under the Creative Commons license, users will need to obtain permission from the license holder to reproduce the material. To view a copy of this license, visit <http://creativecommons.org/licenses/by/4.0/>

© The Author(s) 2017