

Non-Markovian dynamics of a two-level system in the presence of hierarchical environments

Zhong-Xiao Man,^{1,*} Nguyen Ba An,^{2,3} and Yun-Jie Xia^{1,4}

¹*Shandong Provincial Key Laboratory of Laser Polarization and Information Technology, Department of Physics, Qufu Normal University, Qufu 273165, China*

²*Center for Theoretical Physics, Institute of Physics, Vietnam Academy of Science and Technology (VAST), 18 Hoang Quoc Viet, Cau Giay, Hanoi, Vietnam*

³*nban@iop.vast.ac.vn*

⁴*yjxia@mail.qfnu.edu.cn*

**manzhongxiao@163.com*

Abstract: Dynamics of an open system is vividly influenced by the structure of environments. This paper studies in detail the dynamics of a two-level atom in the presence of an overall environment composed of two hierarchies. The first hierarchy is just a single lossy cavity while the second hierarchy consists of a number of other lossy cavities. The atom is coupled directly to the first hierarchy but indirectly to the second one via the couplings between the two hierarchies. We show that even when the coupling between the atom and the first hierarchy is weak the atom's dynamics can become non-Markovian if the number of cavities in the second hierarchy or/and the coupling between the two hierarchies are large enough. We also analyze the case when the coupling between the atom and the first hierarchy is strong and show that the non-Markovian dynamics exhibits different patterns depending on both the number of cavities in the second hierarchy and the coupling between the two hierarchies.

© 2015 Optical Society of America

OCIS codes: (270.0270) Quantum optics; (270.2500) Fluctuations, relaxations, and noise; (270.5580) Quantum electrodynamics.

References and links

1. H.-P. Breuer and F. Petruccione, *Theory of Open Quantum Systems* (Oxford University Press, 2002).
2. M. Nielsen and I. Chuang, *Quantum Computation and Quantum Information* (Cambridge University Press, Cambridge, 2000).
3. W. M. Zhang, M. H. Wu, C. U. Lei, and H. N. Xiong, "Non-Markovian dynamics of a microcavity coupled to a waveguide in photonic crystals," *Opt. Express* **18**, 18407-18418 (2010).
4. G. Harel, A. Kofman, A. Kozhekin, and G. Kurizki, "Control of non-Markovian decay and decoherence by measurements and interference," *Opt. Express* **2**, 355-367 (1998).
5. H. Lee, Y.-C. Cheng, and G. R. Fleming, "Coherence dynamics in photosynthesis: protein protection of excitonic coherence," *Science* **316**, 1462-1465 (2007).
6. L. S. Cederbaum, E. Gindensperger, and I. Burghardt, "Short-time dynamics through conical intersections in macrosystems," *Phys. Rev. Lett.* **94**, 113003 (2005).
7. J. Piilo, S. Maniscalco, K. Härkönen, and K.-A. Suominen, "Non-Markovian quantum jumps," *Phys. Rev. Lett.* **100**, 180402 (2008).
8. J. Piilo, K. Härkönen, S. Maniscalco, and K.-A. Suominen, "Open system dynamics with non-Markovian quantum jumps," *Phys. Rev. A* **79**, 062112 (2009).
9. P. Rebentrost and A. Aspuru-Guzik, "Exciton-phonon information flow in the energy transfer process of photosynthetic complexes," *J. Chem. Phys.* **134**, 101103 (2011).

10. T. J. G. Apollaro, C. Di Franco, F. Plastina, and M. Paternostro, "Memory-keeping effects and forgetfulness in the dynamics of a qubit coupled to a spin chain," *Phys. Rev. A* **83**, 032103 (2011).
11. W. A. Coish and D. Loss, "Hyperfine interaction in a quantum dot: non-Markovian electron spin dynamics," *Phys. Rev. B* **70**, 195340 (2004).
12. W. Yao, R.-B. Liu, and L. J. Sham, "Theory of electron spin decoherence by interacting nuclear spins in a quantum dot," *Phys. Rev. B* **74**, 195301 (2006).
13. J. M. Taylor, J. R. Petta, A. C. Johnson, A. Yacoby, C.M. Marcus, and M. D. Lukin, "Relaxation, dephasing, and quantum control of electron spins in double quantum dots," *Phys. Rev. B* **76**, 035315 (2007).
14. K. H. Madsen, S. Ates, T. Lund-Hansen, A. Löffler, S. Reitzenstein, A. Forchel, and P. Lodahl, "Observation of non-Markovian dynamics of a single quantum dot in a micropillar cavity," *Phys. Rev. Lett.* **106**, 233601 (2011).
15. U. Hoeppe, C. Wolff, J. Küchenmeister, J. Niegemann, M. Drescher, H. Benner, and K. Busch, "Direct observation of non-Markovian radiation dynamics in 3D bulk photonic crystals," *Phys. Rev. Lett.* **108**, 043603 (2012).
16. E. Barnes, Lukasz Cywiński, and S. Das Sarma, "Nonperturbative master equation solution of central spin dephasing dynamics," *Phys. Rev. Lett.* **109**, 140403 (2012).
17. D. M. Kennes, O. Kashuba, M. Pletyukhov, H. Schoeller, and V. Meden, "Oscillatory dynamics and non-Markovian memory in dissipative quantum systems," *Phys. Rev. Lett.* **110**, 100405 (2013).
18. A. Bermudez, T. Schaetz, and M. B. Plenio, "Dissipation-assisted quantum information processing with trapped ions," *Phys. Rev. Lett.* **110**, 110502 (2013).
19. B. Bellomo, R. Lo Franco, and G. Compagno, "Entanglement dynamics of two independent qubits in environments with and without memory," *Phys. Rev. A* **77**, 032342 (2008).
20. B. Bellomo, R. Lo Franco, and G. Compagno, "Non-Markovian effects on the dynamics of entanglement," *Phys. Rev. Lett.* **99**, 160502 (2007).
21. M. del Rey, A.W. Chin, S. F. Huelga, and M. B. Plenio, "Exploiting structured environments for efficient energy transfer: the phonon antenna mechanism," *J. Phys. Chem. Lett.* **4**, 903-907 (2013).
22. S. F. Huelga, À. Rivas, and M. B. Plenio, "Non-Markovianity-assisted steady state entanglement," *Phys. Rev. Lett.* **108**, 160402 (2012).
23. A. W. Chin, S. F. Huelga, and M. B. Plenio, "Quantum metrology in non-Markovian environments," *Phys. Rev. Lett.* **109**, 233601 (2012).
24. A. D'Arrigo, R. Lo Franco, G. Benenti, E. Paladino, and G. Falci, "Recovering entanglement by local operations," *Ann. Phys.* **350**, 211-224 (2014).
25. A. Orioux, A. d'Arrigo, G. Ferranti, R. Lo Franco, G. Benenti, E. Paladino, G. Falci, F. Sciarrino, and P. Mataloni, "Experimental on-demand recovery of entanglement by local operations within non-Markovian dynamics," *Sci. Rep.* (to be published).
26. B. Bellomo, G. Compagno, R. Lo Franco, A. Ridolfo, and S. Savasta, "Dynamics and extraction of quantum discord in a multipartite open system," *Int. J. Quant. Inf.* **9**, 1665-1676 (2011).
27. D. Chruściński and S. Maniscalco, "Degree of non-Markovianity of quantum evolution," *Phys. Rev. Lett.* **112**, 120404 (2014).
28. C. Addis, B. Bylicka, D. Chruściński, and S. Maniscalco, "Comparative study of non-Markovianity measures in exactly solvable one- and two-qubit models," *Phys. Rev. A* **90**, 052103 (2014).
29. B. Bylicka, D. Chruściński, and S. Maniscalco, "Non-Markovianity and reservoir memory of quantum channels: a quantum information theory perspective," *Sci. Rep.* **4**, 5720 (2014).
30. R. Lo Franco, G. Compagno, A. Messina, and A. Napoli, "Generating and revealing a quantum superposition of electromagnetic-field binomial states in a cavity," *Phys. Rev. A* **76**, 011804 (2007).
31. R. Lo Franco, B. Bellomo, S. Maniscalco, and G. Compagno, "Dynamics of quantum correlations in two-qubit systems within non-Markovian environments," *Int. J. Mod. Phys. B* **27**, 1345053 (2013).
32. R. Lo Franco, A. D'Arrigo, G. Falci, G. Compagno, and E. Paladino, "Entanglement dynamics in superconducting qubits affected by local bistable impurities," *Phys. Scr.* **T147**, 014019 (2012).
33. J. Dajka and J. Luczka, "Distance growth of quantum states due to initial system-environment correlations," *Phys. Rev. A* **82**, 012341 (2010).
34. A. Smirne, H.P. Breuer, J. Piilo, and B. Vacchini, "Initial correlations in open-systems dynamics: the Jaynes-Cummings model," *Phys. Rev. A* **82**, 062114 (2010).
35. Z. X. Man, A. Smirne, Y.J. Xia, and B. Vacchini, "Quantum interference induced by initial system-environment correlations," *Phys. Letts. A* **376**, 2477-2483 (2012).
36. C. F. Li, J. S. Tang, Y. L. Li, and G. C. Guo, "Experimentally witnessing the initial correlation between an open quantum system and its environment," *Phys. Rev. A* **83**, 064102 (2011).
37. R. Lo Franco, B. Bellomo, E. Andersson, and G. Compagno, "Revival of quantum correlations without system-environment back-action," *Phys. Rev. A* **85**, 032318 (2012).
38. J. S. Xu, K. Sun, C. F. Li, X. Y. Xu, G. C. Guo, E. Andersson, R. L. Franco, and G. Compagno, "Experimental recovery of quantum correlations in absence of system-environment back-action," *Nat. Commun.* **4**, 2851 (2013).
39. E. M. Laine, H. P. Breuer, J. Piilo, C. F. Li, and G. C. Guo, "Nonlocal memory effects in the dynamics of open quantum systems," *Phys. Rev. Lett.* **108**, 210402 (2012).
40. B. H. Liu, D. Y. Cao, Y. F. Huang, C. F. Li, G. C. Guo, E. M. Laine, H. P. Breuer, and J. Piilo, "Photonic

- realization of nonlocal memory effects and non-Markovian quantum probes,” *Sci. Rep.* **3**, 1781 (2013).
41. H. P. Breuer, E.-M. Laine, and J. Piilo, “Measure for the degree of non-Markovian behavior of quantum processes in open systems,” *Phys. Rev. Lett.* **103**, 210401 (2009).
 42. S. Lorenzo, F. Plastina, and M. Paternostro, “Geometrical characterization of non-Markovianity,” *Phys. Rev. A* **88**, 020102 (2013).
 43. Á. Rivas, S. F. Huelga, and M. B. Plenio, “Entanglement and non-Markovianity of quantum evolutions,” *Phys. Rev. Lett.* **105**, 050403 (2010).
 44. J. Cerrillo and J. Cao, “Non-Markovian dynamical maps: numerical processing of open quantum trajectories,” *Phys. Rev. Lett.* **112**, 110401 (2014).
 45. C.-K. Chan and L. J. Sham, “Precision of electromagnetic control of a quantum system,” *Phys. Rev. A* **84**, 032116 (2011).
 46. R. Hanson, L. P. Kouwenhoven, J. R. Petta, S. Tarucha, and L. M. Vandersypen, “Spins in few-electron quantum dots,” *Rev. Mod. Phys.* **79**, 1217 (2007).
 47. E. A. Chekhovich, M. N. Makhonin, A. I. Tartakovskii, A. Yacoby, H. Bluhm, K. C. Nowack, and L. M. Vandersypen, “Nuclear spin effects in semiconductor quantum dots,” *Nat. Mater.* **12**, 494-504 (2013).
 48. R. Hanson, V. V. Dobrovitski, A. E. Feiguin, O. Gywat, and D. D. Awschalom, “Coherent dynamics of a single spin interacting with an adjustable spin bath,” *Science* **320**, 352-355 (2008).
 49. J. J. Pla, K. Y. Tan, J. P. Dehollain, W. H. Lim, J. J. L. Morton, D. N. Jamieson, A. S. Dzurak, and A. Morello, “A single-atom electron spin qubit in silicon,” *Nature (London)* **489**, 541-545 (2012).
 50. A. M. Tyryshkin et al., “Electron spin coherence exceeding seconds in high-purity silicon,” *Nat. Mater.* **11**, 143-147 (2012).
 51. C.-K. Chan, G.-D. Lin, S. F. Yelin, and M. D. Lukin, “Quantum interference between independent reservoirs in open quantum systems,” *Phys. Rev. A* **89**, 042117 (2014).
 52. Tony J. G. Apollaro, S. Lorenzo, C. D. Franco, F. Plastina, and M. Paternostro, “Competition between memory-keeping and memory-erasing decoherence channels,” *Phys. Rev. A* **90**, 012310 (2014).
 53. Z. X. Man, N. B. An, and Y. J. Xia, “Non-Markovianity of a two-level system transversally coupled to multiple bosonic reservoirs,” *Phys. Rev. A* **90**, 062104 (2014).
 54. T. Ma, Y. Chen, T. Chen, S. R. Hedemann, and T. Yu, “Crossover between non-Markovian and Markovian dynamics induced by a hierarchical environment,” *Phys. Rev. A* **90**, 042108 (2014).
 55. B. M. Garraway, “Nonperturbative decay of an atomic system in a cavity,” *Phys. Rev. A* **55**, 2290 (1997).
 56. S. Wissmann, A. Karlsson, E.-M. Laine, J. Piilo, and H.-P. Breuer, “Optimal state pairs for non-Markovian quantum dynamics,” *Phys. Rev. A* **86**, 062108 (2012).
 57. L. Mazzola, S. Maniscalco, J. Piilo, K. A. Suominen, and B. M. Garraway, “Pseudomodes as an effective description of memory: non-Markovian dynamics of two-state systems in structured reservoirs,” *Phys. Rev. A* **80**, 012104 (2009).
-

1. Introduction

The dynamics of open quantum systems is not only a fundamental issue [1] but also relevant to the realization of quantum information technology [2] that employs practical quantum systems as basic resources. In application, the unavoidable influences of various surroundings make the useful characters of a quantum system, such as coherence and entanglement, degrade with time. In this connection, a lot of efforts have been devoted towards a thorough understanding of open system dynamics in various practical environments. From a point of view of information flow between the system and the environment, the system’s dynamics can be divided into two categories: Markovian dynamics when the information flows only one-way, from the system to the environment, and non-Markovian one when, thanks to the memory effect of the environment, the information can flow two-way, from the system to the environment and vice versa. Recently, the non-Markovian dynamics has attracted ever increasing interests [3–18], partially because of its domination in practical physical processes and usefulness in schemes relying on non-Markovian evolutions, such as quantum-state engineering and quantum control [19–32]. So far, many factors that can trigger non-Markovian dynamics have been found, for example, strong system-environment coupling, structured reservoirs, low temperatures, and initial system-environment correlations [33–36]. Apart from those conventional scenarios, some anomalous ones have also been found enabling emergence of non-Markovian dynamics. As reported in Ref. [37], revivals of quantum correlations of a composite system may occur even when the environment is classical and does not back react on the quantum

system. Such a prediction has been realized in an all-optical experiment [38]. Furthermore, for a bipartite open system with each of its subsystems locally interacting with a subsystem of a composite environment, the initial correlations between the subsystems of the environment can lead to non-Markovian behavior of the total open system, although the local dynamics of both subsystems of the system are Markovian [39]. Subsequently, an experimental demonstration of that phenomenon has also been achieved by using photonic open system [40]. These results hint that the origin of non-Markovian dynamics is very subtle and there remain unknown causes for non-Markovian dynamics. In order to quantify the degree of a non-Markovian process, i.e., the so-called non-Markovianity, several measures have been proposed, such as the Breuer-Laine-Piilo measure based on the distinguishability between different initial states of the system [41], the Lorenzo-Plastina-Paternostro measure based on the volume of accessible states of the system [42], and the Rivas-Huelga-Plenio measure based on the entanglement that the system shares with an ancilla [43]. Recently, some new methods are also proposed to deal with non-Markovian environment, such as the quantum trajectory [44] and diagrammatic approaches [45].

Although a system being coupled to a single environment is a commonplace for studying the open system dynamics, in many realistic situations the system of interest is simultaneously affected by several environments. For example, the electron spin in a quantum dot may at the same time be influenced strongly by the surrounding nuclei and weakly by the phonons [46,47]. The surrounding nitrogen impurities constitute the principal bath for a nitrogen-vacancy center, while the carbon-13 nuclear spins also have some influences on it [48]. Similar scenario occurs for a single-donor electron spin in silicon [49, 50]. Motivated by these realistic scenarios, explorations are made regarding the dynamical behaviors of an open system in the presence of multiple environments. In Ref. [51], it is found that when a quantum system interacts with multiple non-Markovian environments, quantum interference effect occurs between the independent environments, which can qualitatively modify the dynamics of the interested system. Reference [52] studies the dynamics of a single spin being simultaneously coupled to two decoherence channels, one is Markovian and the other is non-Markovian. The competition of the two channels and the condition for the occurrence of non-Markovian dynamics is considered for different decoherence mechanisms [52]. It is known that the dynamics of a two-level atom that is coupled to a single vacuum bosonic reservoir may be Markovian or non-Markovian depending on whether the atom-reservoir coupling is weak or strong [1]. However, if the atom is simultaneously coupled to several reservoirs its dynamics is always (i.e., independent of the coupling strength between the system and a reservoir) non-Markovian provided that the number of the contributed reservoirs is not less than a critical value depending on the reservoirs' parameters [53]. In Ref. [54], the authors study the dynamics of a two-level atom coupled to a composite environment that is composed of a single-mode cavity and a structured reservoir with a Lorentzian spectrum. They focus on how the atom dynamics is influenced by the atom-cavity coupling strength and the reservoir memory time. For any given reservoir memory time, the atom experiences a crossover from Markovian to non-Markovian dynamics when the atom-cavity coupling is increasing. However, for certain values of the atom-cavity coupling, the atom dynamics exhibits two crossovers, one from non-Markovian to Markovian and the other from Markovian to non-Markovian, as the reservoir memory time is decreasing [54]. That is, a shorter (longer) memory time of the reservoir does not universally mean a weaker (stronger) non-Markovianity of the system.

In this work, we study the dynamics of a two-level system in the presence of an overall environment hierarchically structured as follows. The system is only coupled to the first hierarchy of the environment, which is in turn connected to the second one. We are interested in the effects of the coupling strength between the two hierarchies and the size of the second hierarchy

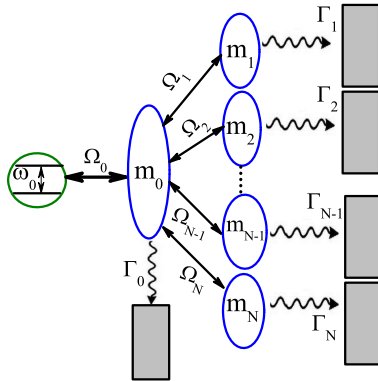

Fig. 1. A two-level system (circle) is coupled with strength Ω_0 to a mode (large ellipse) m_0 which decays to a memoryless reservoir (rectangle) with a rate Γ_0 . The mode m_0 is further coupled simultaneously with strengths $\Omega_1, \Omega_2, \dots, \Omega_N$ to modes m_1, m_2, \dots, m_N (small ellipses) which also decay to their respective memoryless reservoirs (rectangles) with rates $\Gamma_1, \Gamma_2, \dots, \Gamma_N$.

on the system's dynamics, focusing on the non-Markovianity of the system. It is known that in the absence of the second environmental hierarchy, such as the case of a two-level system transversally coupled to a vacuum bosonic reservoir [1], the system will exhibit Markovian dynamics in the weak coupling regime and non-Markovian dynamics in the strong coupling regime. Therefore, we carry out our study in both the weak and the strong coupling regimes between the system and the first environmental hierarchy. As we shall show in this work, even in the weak coupling regime the dynamics of the system can still become non-Markovian if the coupling strength between the two environmental hierarchies and/or the size of the second hierarchy satisfy certain conditions. Moreover, the backflow of information could occur without the requirement for the system to decay to its ground state that is nevertheless necessary in the conventional models of a two-level system being transversely coupled to a single [1] or multiple reservoirs [53]. As a result, a larger non-Markovianity can be achieved without the cost of faster decay of the system. In the strong coupling regime, we shall show that under the influence of the second environmental hierarchy the system's non-Markovian dynamics would exhibit different patterns along with the variations of the coupling strengths between the two hierarchies of the environment.

2. The model

The model we shall study is sketched in Fig. 1. A two-level system is coupled with strength Ω_0 to a mode m_0 which decays to a memoryless reservoir with a rate Γ_0 . The mode m_0 and its corresponding damping reservoir comprise the first hierarchy of the environment. If there are no any other environmental hierarchies, the system's dynamics depends on the parameters Ω_0 and Γ_0 in such a way that $\Omega_0 < \Gamma_0/4$ ($\Omega_0 > \Gamma_0/4$), identified as the weak (strong) coupling regime, leads to Markovian (non-Markovian) dynamics. In the present model, the mode m_0 is further coupled simultaneously with strengths $\Omega_1, \Omega_2, \dots, \Omega_N$ to modes m_1, m_2, \dots, m_N which decay to their respective memoryless reservoirs with decay rates $\Gamma_1, \Gamma_2, \dots, \Gamma_N$. The modes m_1, m_2, \dots, m_N

and their associated reservoirs form the second hierarchy of the environment. To keep a visualized picture in mind, we map our general model to a more practical scenario as follows. The system s we are interested in is specified as a two-level atom which is placed inside a single-mode lossy cavity m_0 with decay rate Γ_0 . The cavity m_0 is in turn at the same time coupled to N ($N \geq 1$) other lossy cavities m_1, m_2, \dots, m_N with decay rates $\Gamma_1, \Gamma_2, \dots, \Gamma_N$, respectively. The total Hamiltonian can be written as $H = H_0 + H_I$, where H_0 is the free Hamiltonian of the atom plus $N + 1$ cavities,

$$H_0 = \frac{\omega_s}{2} \sigma_z + \omega_c a^\dagger a + \sum_{n=1}^N \omega_n b_n^\dagger b_n, \quad (1)$$

and H_I is composed of two parts: one describes the s - m_0 coupling of the atom s with the cavity m_0 and the other describes m_0 - m_n ($n = 1, 2, \dots, N$) coupling between the cavity m_0 and each of the remaining N cavities m_1, m_2, \dots, m_N ,

$$H_I = \Omega_0(\sigma_+ a + \sigma_- a^\dagger) + \sum_{n=1}^N \Omega_n(ab_n^\dagger + a^\dagger b_n). \quad (2)$$

In Eqs. (1) and (2), ω_s is the atomic level spacing and σ_\pm denote the lowering and raising operators of the atom, a (a^\dagger) and b_n (b_n^\dagger) are the bosonic annihilation (creation) operators for cavity m_0 with frequency ω_c and the n th cavity m_n with frequency ω_n , while Ω_0 and Ω_n stand for the corresponding couplings. In practice, the nonperfect reflectivity of the cavity mirrors lead to the loss of photon, therefore it is relevant to take the dissipations of all the cavities into account. In this case, the density operator $\rho(t)$ of the total system (i.e., the atom plus the $N + 1$ cavities) obeys the following master equation

$$\begin{aligned} \dot{\rho}(t) = & -i[H, \rho(t)] - \frac{\Gamma_0}{2}[a^\dagger \rho(t) - 2a\rho(t)a^\dagger + \rho(t)a^\dagger a] \\ & - \sum_{n=1}^N \frac{\Gamma_n}{2}[b_n^\dagger b_n \rho(t) - 2b_n \rho(t)b_n^\dagger + \rho(t)b_n^\dagger b_n], \end{aligned} \quad (3)$$

where Γ_0 and Γ_n denote, as mentioned above, the decay rates of cavities m_0 and m_n , respectively. Generally, an environment may have a finite memory time so that the master equation is not necessarily in the time-independent Lindblad form. Here, however, we are only concerned with a particular situation where non-Markovianity is generated by a drive (Ω_j with $j = 0, 1, 2, \dots, N$) plus a Lindblad decay.

We consider the situation in which the atom is initially in its excited state $|1\rangle_s$, while all the cavities are in their ground states $|00\dots 0\rangle_{m_0 m_1 \dots m_N}$, i.e., the total initial state is $\rho_{s,m}(0) \equiv \rho_{s,m_0,m_1,\dots,m_N}(0) = |\psi(0)\rangle_{s,m} \langle\psi(0)|$ with $|\psi(0)\rangle_{s,m} = |10\dots 0\rangle_{s,m} \equiv |1\rangle_s \otimes |00\dots 0\rangle_{m_0 m_1 \dots m_N}$. Since there exist at most one excitation in the total system at a time, we make the ansatz for $\rho_{s,m}(t)$ at time t in the form

$$\rho_{s,m}(t) = (1 - \lambda(t)) |\psi(t)\rangle_{s,m} \langle\psi(t)| + \lambda(t) |00\dots 0\rangle_{s,m} \langle 00\dots 0|, \quad (4)$$

where $0 \leq \lambda(t) \leq 1$ with $\lambda(0) = 0$ and $|\psi(t)\rangle_{s,m} = h(t) |10\dots 0\rangle_{s,m} + c_0(t) |01\dots 0\rangle_{s,m} + \dots + c_N(t) |00\dots 1\rangle_{s,m}$ with $h(0) = 1$ and $c_0(0) = c_1(0) = \dots = c_N(0) = 0$. It is convenient to introduce the unnormalized state vector [55]

$$\begin{aligned} |\tilde{\psi}(t)\rangle_{s,m} & \equiv \sqrt{1 - \lambda(t)} |\psi(t)\rangle_{s,m} \\ & = \tilde{h}(t) |10\dots 0\rangle_{s,m} + \tilde{c}_0(t) |01\dots 0\rangle_{s,m} + \dots + \tilde{c}_N(t) |00\dots 1\rangle_{s,m}, \end{aligned} \quad (5)$$

where $\tilde{h}(t) \equiv \sqrt{1-\lambda(t)}h(t)$ represents the probability amplitude of the atom and $\tilde{c}_n(t) \equiv \sqrt{1-\lambda(t)}c_n(t)$ that of the n th cavity being in its excited state. Then, in terms of the unnormalized state vector,

$$\rho_{s,m}(t) = |\tilde{\Psi}(t)\rangle_{s,m} \langle \tilde{\Psi}(t)| + \lambda(t) |00\dots 0\rangle_{s,m} \langle 00\dots 0|. \quad (6)$$

Governed by the Hamiltonians Eq. (1) and Eq. (2), the time-dependent amplitudes $\tilde{h}(t)$, $\tilde{c}_0(t)$, ..., $\tilde{c}_N(t)$ in Eq. (5) are determined by a set of differential equations as

$$i\frac{d\tilde{h}(t)}{dt} = \omega_s\tilde{h}(t) + \Omega_0\tilde{c}_0(t), \quad (7)$$

$$i\frac{d\tilde{c}_0(t)}{dt} = \left(\omega_c - \frac{i}{2}\Gamma_0\right)\tilde{c}_0(t) + \Omega_0\tilde{h}(t) + \sum_{n=1}^N \Omega_n\tilde{c}_n(t), \quad (8)$$

$$i\frac{d\tilde{c}_n(t)}{dt} = \left(\omega_n - \frac{i}{2}\Gamma_n\right)\tilde{c}_n(t) + \Omega_n\tilde{c}_0(t), \quad n = 1, 2, \dots, N. \quad (9)$$

We can solve the above differential equations by means of Laplace transformations combined with numerical simulations to obtain the reduced density operators of the atom as well as of each of the involved cavities.

The degree of a non-Markovian process can be quantified by the so-called non-Markovianity in terms of different measures [41–43], as mentioned above. Here, we adopt the dynamics of trace distance between two different initial states $\rho_1(0)$ and $\rho_2(0)$ of an open system to witness and quantify the non-Markovianity [41]. A Markovian evolution can never increase the trace distance, hence violation of the contractiveness of the trace distance would signify non-Markovian dynamics of the system. Based on this concept, the non-Markovianity can be quantified by a measure \mathcal{N} defined as [41]

$$\mathcal{N} = \max_{\rho_1(0), \rho_2(0)} \int_{\sigma > 0} \sigma[t, \rho_1(0), \rho_2(0)] dt, \quad (10)$$

in which $\sigma[t, \rho_1(0), \rho_2(0)] = dD[\rho_1(t), \rho_2(t)]/dt$ is the rate of change of the trace distance given by

$$D[\rho_1(t), \rho_2(t)] = \frac{1}{2} \text{Tr}|\rho_1(t) - \rho_2(t)|, \quad (11)$$

where $|X| = \sqrt{X^\dagger X}$. In order to evaluate the non-Markovianity \mathcal{N} , we have to find a specific pair of optimal initial states to maximize the time derivative of the trace distance. In Ref. [56], it is proved that the pair of optimal states is associated with two antipodal pure states on the surface of the Bloch sphere. We can thus take $\rho_1(0) = |+\rangle\langle +|$ and $\rho_2(0) = |-\rangle\langle -|$, with $|\pm\rangle = (|0\rangle \pm |1\rangle)/\sqrt{2}$, as the optimal pair of initial states throughout the paper. This allows us to derive the time derivative of the trace distance in the simple form

$$\sigma[t, \rho_1(0), \rho_2(0)] = \frac{d|\tilde{h}(t)|}{dt}. \quad (12)$$

3. Markovian versus non-Markovian dynamics

It has been known so far that, for a two-level atom embedded in a lossy cavity, the atom exhibits Markovian dynamics in the weak (strong) atom-cavity coupling regime determined by the inequality $\Omega_0 < \Gamma_0/4$ ($\Omega_0 > \Gamma_0/4$). Naturally, in order to achieve a non-Markovian dynamics, one has either to increase the atom-cavity coupling strength Ω_0 for a given cavity decay rate

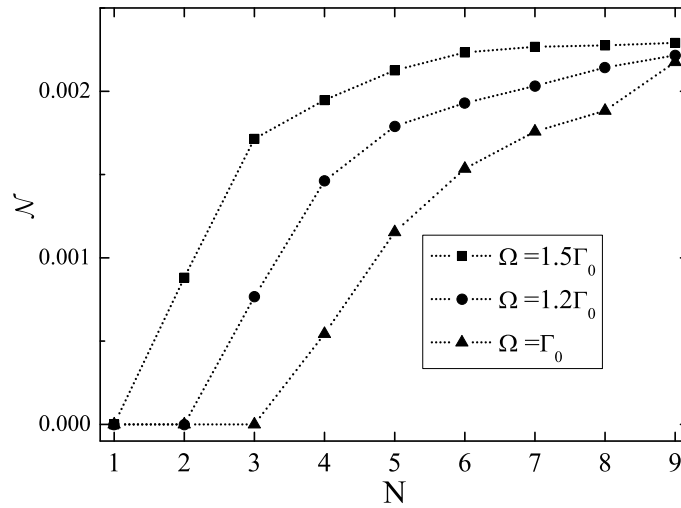

Fig. 2. The non-Markovianity \mathcal{N} as a function of the number N of identical cavities m_n ($n = 1, 2, \dots, N$) for different values of the m_0 - m_n coupling strength Ω ($= \Omega_n \forall n$) but fixed values of the s - m_0 coupling strength $\Omega_0 = \Gamma_0/5$ and the cavity m_n decay rate Γ ($= \Gamma_n \forall n$) = Γ_0 .

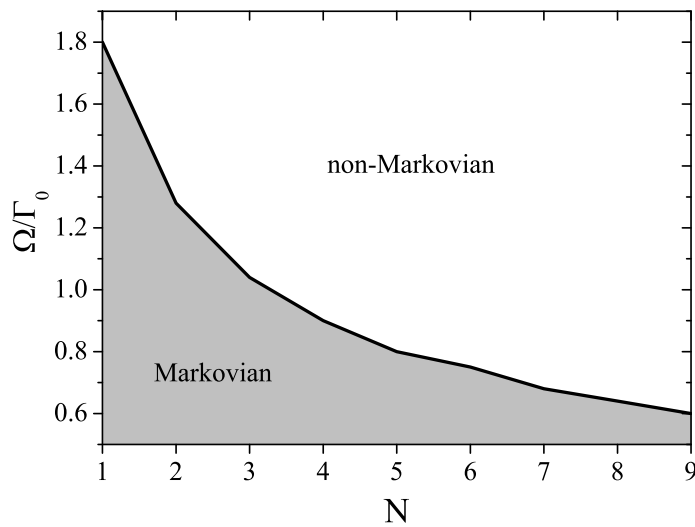

Fig. 3. Phase diagram in the N - Ω/Γ_0 plane for the crossover between Markovian and non-Markovian dynamics in the weak s - m_0 coupling regime with $\Omega_0/\Gamma_0 = 0.2$ while $\Gamma = \Gamma_0$.

Γ_0 or to improve the cavity quality by reducing Γ_0 for a fixed Ω_0 . However, retaining in the weak coupling regime (i.e., Ω_0 and Γ_0 are such that the ratio $4\Omega_0/\Gamma_0$ cannot be for some reasons made greater than 1), how one can transform the dynamics from Markovian to non-Markovian is an interesting issue. Here, we show that if the cavity m_0 is let be further coupled simultaneously to some other cavities m_1, m_2, \dots, m_N , then qualitative changes in behavior of the atom dynamics may occur. In Fig. 2, we display the dependence of the non-Markovianity \mathcal{N} on the number N of the secondary cavities m_1, m_2, \dots, m_N and on the coupling strengths Ω_n ($n = 1, 2, \dots, N$), when the s - m_0 coupling is weak. Without losing the physics feature of interest, we assume for simplicity identical reservoirs with $\Gamma_n = \Gamma$ and $\Omega_n = \Omega$ for $n \in \{1, 2, \dots, N\}$. As shown in Fig. 2, for a relatively small m_0 - m_n coupling strength, say, $\Omega = \Gamma_0$, the atom dynamics remains Markovian ($\mathcal{N} = 0$) up to $N = 3$, but becomes non-Markovian ($\mathcal{N} > 0$) starting from $N = 4$. However, non-Markovian dynamics is induced already from $N = 3$ ($N = 2$) for an increased m_0 - m_n coupling strength, say, $\Omega = 1.2\Gamma_0$ ($\Omega = 1.5\Gamma_0$). In general, the non-Markovianity \mathcal{N} increases with N (Ω) for a given Ω (N). We thus have two parameters, N and Ω , that can be controlled to trigger non-Markovian dynamics as well as to manage the non-Markovianity. Remarkably, this is an efficient alternative way to achieve non-Markovian dynamics from Markovian dynamics in cases when direct manipulations of the s - m_0 coupling strength Ω_0 and decay rate Γ_0 are unavailable. The phase diagram in the N - Ω/Γ_0 plane plotted in Fig. 3 clearly shows the crossover between Markovian and non-Markovian dynamics. For a given N (Ω/Γ_0) Markovian dynamics may turn out to be non-Markovian if Ω/Γ_0 (N) is getting large enough and vice versa. Although we consider equal coupling strengths and decay rates for the leaky cavities in the second hierarchy, the general picture remains the same for the case of inhomogeneous couplings. Actually, as we shall show below, the presence of secondary cavities drives the cavity m_0 to its ground state in a finite time, but for a later time m_0 can reabsorb the energy stored in the secondary cavities to return them to the atom inducing the non-Markovian dynamics. Obviously, that process is due to the coupling of the cavity m_0 to the overall (rather than individual) cavities in the second hierarchy, so inhomogeneous couplings would not bring any qualitative change compared with homogeneous ones.

In the model under consideration, the information of the atom flows firstly to the cavity m_0 and then to the cavities m_1, m_2, \dots, m_N , while the retrieve of the decayed information from the cavity m_0 signifies the occurrence of non-Markovian dynamics of the atom. In the absence of any of the cavities m_1, m_2, \dots, m_N , a strong s - m_0 coupling can force a backflow of the information, but a weak one cannot. In the presence of the cavities m_1, m_2, \dots, m_N , however, even a weak s - m_0 coupling could induce the non-Markovian dynamics under appropriate conditions to be satisfied by N and Ω_n . Although non-Markovian dynamics occurs in both the two above-mentioned situations, the patterns of their curves are different, which represents different mechanisms that cause the non-Markovian dynamics. In Fig. 4, we demonstrate two different non-Markovian dynamics patterns through the time-evolution of the trace distance with emphasis on the moments at which the trace distance starts to grow. We choose $\Omega_0 = 0.3\Gamma_0$ ($> \Gamma_0/4$, i.e., the s - m_0 coupling is strong) under the situation with no secondary cavities, while $\Omega_0 = 0.2\Gamma_0$ ($< \Gamma_0/4$, i.e., the s - m_0 coupling is weak) when some secondary cavities are involved. For concreteness, in the latter situation the cavity m_0 is assumed coupled with two identical cavities m_1 and m_2 with the same coupling strengths $\Omega = \Omega_1 = \Omega_2 = \Gamma_0$ and decay rates $\Gamma = \Gamma_1 = \Gamma_2 = 0.5\Gamma_0$. From the shape of trace distance evolution in Fig. 4, we observe that though in both situations the evolution of the trace distances is not monotonic, their patterns exhibit clear distinctions. In the strong s - m_0 coupling regime without any other secondary cavities [Fig. 4(a)] the trace distance first decreases until touching the zero line and then gets back to be positive (we call this type I pattern). We know that only when two states become indistinguishable can their trace distance be zero, therefore the atom must have decayed to its

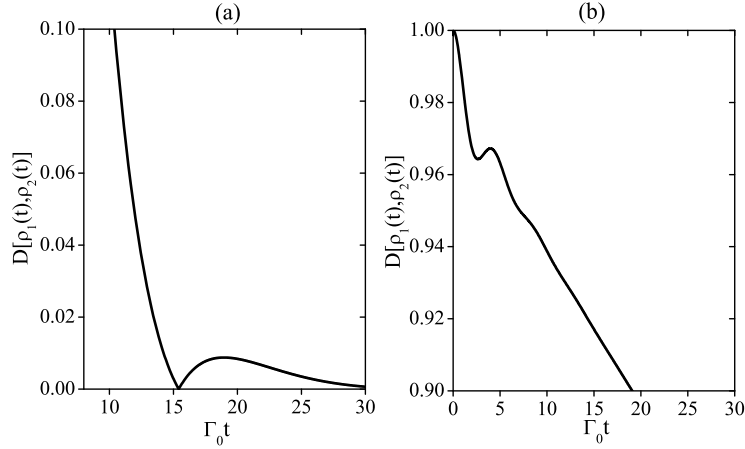

Fig. 4. The trace distance evolution showing (a) type I pattern for the case of strong s - m_0 coupling with $\Omega_0 = 0.3\Gamma_0$ in the absence of any additional cavity and (b) type II pattern for the case of weak s - m_0 coupling with $\Omega_0 = 0.2\Gamma_0$ in the presence of two identical additional cavities with $\Omega = \Omega_1 = \Omega_2 = \Gamma_0$ and $\Gamma = \Gamma_1 = \Gamma_2 = 0.5\Gamma_0$.

ground state before regaining part of the lost information. In other words, a strong s - m_0 coupling drives the atom decay to its ground state during a finite time so that the further interaction with m_0 that possesses a photon with nonzero probability results in the information backflow from the cavity to the atom. In this case, an achievement of non-Markovian dynamics usually implies a faster decay of the atom. By contrast, in the weak s - m_0 coupling regime but, when the cavities m_1, m_2, \dots, m_N are present [Fig. 4(b)], the trace distance first decreases, then, at some moment during its evolution, turns out to grow up to a maximal value, and after that approaches to zero in the long-time limit (we call this type II pattern). That is, contrary to the strong s - m_0 coupling regime without any additional cavities, the atom can reabsorb the lost information from the cavity m_0 without the need to decay to its ground state. Therefore, the non-Markovian dynamics as well as the larger non-Markovianity can be achieved without the cost of faster decay of the atom. The two above-mentioned pattern types of non-Markovian dynamics are in fact encountered in open systems [54]. To reveal the physics of the transition from Markovian to non-Markovian dynamics with the influence of the secondary cavities in the weak s - m_0 coupling regime, we shall study in the following the energy flux along the atom and the cavities $m_0, m_1, m_2, \dots, m_N$.

The direction of energy flow between the atom and the cavity m_0 can be indicated by the trace distance evolution: an increase (decrease) of which specifies energy transfer from the cavity (atom) to the atom (cavity). To witness the energy flow direction between the cavity m_0 and the n th one m_n , we employ the compensated rate of the population change of the cavity m_n , which in the spirit of Ref. [57] is defined as

$$W_n(t) \equiv \frac{d|\tilde{c}_n(t)|^2}{dt} + \Gamma_n|\tilde{c}_n(t)|^2, \quad (13)$$

where $|\tilde{c}_n(t)|^2$ is the excited state population of the cavity m_n given in Eqs. (7)-(9). If the en-

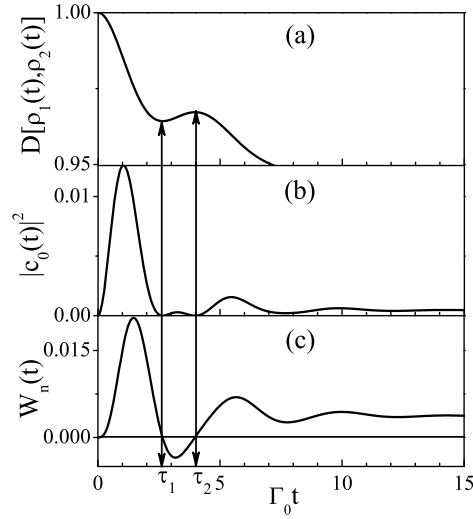

Fig. 5. Evolution of (a) the trace distance, (b) the population $|c_0(t)|^2$ of the cavity m_0 and (c) the witness $W_n(t)$, Eq. (13), for the case when the s - m_0 coupling is weak with $\Omega_0 = 0.2\Gamma_0$ while the cavity m_0 is coupled, with the same strength $\Omega = \Omega_1 = \Omega_2 = \Gamma_0$, to two identical cavities m_1, m_2 , which decay with the same rate $\Gamma = \Gamma_1 = \Gamma_2 = 0.5\Gamma_0$.

ergy of cavity m_n decreases (i.e., $d|\tilde{c}_n(t)|^2/dt < 0$) and meanwhile such a decrease cannot be accounted for by its dissipation determined by the term $\Gamma_n|\tilde{c}_n(t)|^2$ (i.e., $W_n(t) < 0$), then we are sure that energy is flowing from cavity m_n to cavity m_0 . That is, negativity of $W_n(t)$ can serve as a witness of the energy flow from the n th cavity m_n to the cavity m_0 . In Fig. 5 we plot the evolution of the trace distance [Fig. 5(a)], the population $|c_0(t)|^2$ of the cavity m_0 [Fig. 5(b)] as well as the witness $W_n(t)$ [Fig. 5(c)] for the aforementioned situation (i.e., when the atom and the cavity m_0 are in the weak coupling regime) with $\Omega_0 = 0.2\Gamma_0$ while the cavity m_0 is coupled with the same strength $\Omega = \Omega_1 = \Omega_2 = \Gamma_0$ to two cavities m_1, m_2 , which damp with the same rate $\Gamma = \Gamma_1 = \Gamma_2 = 0.5\Gamma_0$. As seen from the figure, at a (scaled) time point $\tau_1 = \Gamma_0 t_1$, when the trace distance decreases to a minimum and starts to grow, the population of cavity m_0 reaches zero and the value of $W_n(t)$ switches from positive to negative. The trace distance keeps growing and $W_n(t)$ keeps being negative until a later time $\tau_2 = \Gamma_0 t_2$, after which the trace distance drops again and $W_n(t)$ switches back from negative to positive. From that observation, we can describe the energy transfer progress as follows. For $\tau (\equiv \Gamma_0 t) < \tau_1$, the energy flows from the atom to cavity m_0 and then to the cavities m_1, m_2, \dots, m_N apart from the dissipations into the associated memoryless reservoirs. The thing changes at $\tau = \tau_1$ at which the cavity m_0 decays to its vacuum state and begins to resorb the lost energy stored in the cavities m_1, m_2, \dots, m_N . Thanks to the existence of the cavities m_1, m_2, \dots, m_N , the energy can flow back from them to the cavity m_0 and then to the atom during the whole period of $\tau_1 < \tau < \tau_2$. Eventually, from $\tau = \tau_2$, the direction of energy flux changes again and the atom is losing energy continuously as time goes on. Here, it is worth noting that the change of the direction of energy flow between the cavity m_0 and the cavities m_1, m_2, \dots, m_N leads to the same change of that between the atom and the cavity m_0 . Therefore, we can conclude that it is the presence of the cavities m_1, m_2, \dots, m_N that determines the emergence of non-Markovian dynamics of the atom in the

weak s - m_0 coupling regime.

4. Patterns of non-Markovian dynamics

If the s - m_0 coupling is weak and there are no other cavities at all, then the atom dynamics can only be Markovian. Nevertheless, as shown in the above discussions, non-Markovian dynamics can be triggered by letting the cavity m_0 be further coupled simultaneously to a number of secondary cavities m_1, m_2, \dots, m_N ($N \geq 1$), no matter they are perfect or lossy. In this section, we proceed to the strong s - m_0 coupling regime in which the atom dynamics is already non-Markovian even without any additional cavities. In this case, the non-Markovian dynamics can be described by type I pattern, as manifested by the trace distance evolution. From a microscopic physical point of view, that type of non-Markovian dynamics pattern is due to re-absorption of lost energy from the cavity m_0 after the atom has decayed to its ground state. Now, we are interested in the non-Markovian patterns when the secondary cavities m_1, m_2, \dots, m_N are involved. We shall show that apart from type I pattern, type II pattern as well as coexistence of these two types may show up as the strengths of m_0 - m_n coupling vary. To be visual, we display in Fig. 6 the transformation of non-Markovian dynamics patterns through the variation of non-Markovianity \mathcal{N} versus the m_0 - m_n couplings Ω/Γ_0 for a fixed s - m_0 coupling strength $\Omega_0 = 0.5\Gamma_0$ ($> \Gamma_0/4$, i.e., in the strong coupling regime). The circles correspond to the situation when only one ($N = 1$) hierarchical cavity is involved, while triangles to the situation when two ($N = 2$) identical cavities m_1 and m_2 with the same coupling strength $\Omega = \Omega_1 = \Omega_2$ and the same decay rate $\Gamma_1 = \Gamma_2 = \Gamma_0$ come into play. The different colors of the symbols denote different patterns of non-Markovian dynamics: the white (black) color is for type I (type II) pattern, while the black-white color represents coexistence of these two types of pattern. Note also that there exist a domain (labeled by crosses) of Ω/Γ_0 within which the non-Markovianity $\mathcal{N} = 0$. Generally, for both cases of $N = 1$ and $N = 2$, when Ω/Γ_0 is increasing, the dynamics changes from type I pattern to type II pattern after experiencing a coexistence of these two types, then, at a critical value of Ω/Γ_0 , suddenly becomes Markovian (i.e., $\mathcal{N} = 0$) and keeps so within a domain of further increase of Ω/Γ_0 , but transforms back to be non-Markovian (i.e., $\mathcal{N} > 0$) with type II pattern, as Ω/Γ_0 continues to increase.

The transformation of non-Markovian dynamics patterns is obviously related to the strength Ω/Γ_0 of the m_0 - m_n couplings. Therefore, we are going to analyze the underlying reason focusing on the values of Ω/Γ_0 in the domains before and after $\mathcal{N} = 0$, respectively. In the strong s - m_0 coupling regime and for the values of Ω/Γ_0 being in the domain before $\mathcal{N} = 0$, both the atom and the cavity m_0 can decay to their respective ground states in a finite time. The former situation leads to non-Markovian dynamics with type I pattern, while the latter situation to type II pattern. Since it requires a relatively large m_0 - m_n coupling to make the cavity m_0 decay to its ground state in a finite time, type II pattern appears posterior with respect to type I one, as shown in Fig. 6. For the in-between values of Ω/Γ_0 , both two situations can take place, resulting in coexistence of those two types of patterns. Moreover, in the domain before $\mathcal{N} = 0$, an increase in Ω/Γ_0 favors dissipation of the atom, therefore the non-Markovianity \mathcal{N} decreases with slight increases of Ω/Γ_0 and eventually becomes zero. In the domain after $\mathcal{N} = 0$, a further increase in Ω/Γ_0 even more favors the atom dissipation so the atom can be thought of as belonging to weak coupling regime with respect to the overall environment (i.e., including all the $N + 1$ cavities $m_0, m_1, m_2, \dots, m_N$). In this case, only finite-time decay of the cavity m_0 to its ground state can take place, which induces the non-Markovian dynamics. That is why we only observe type II pattern of the non-Markovian dynamics. Also, the larger the values of Ω/Γ_0 , the larger the non-Markovianity \mathcal{N} .

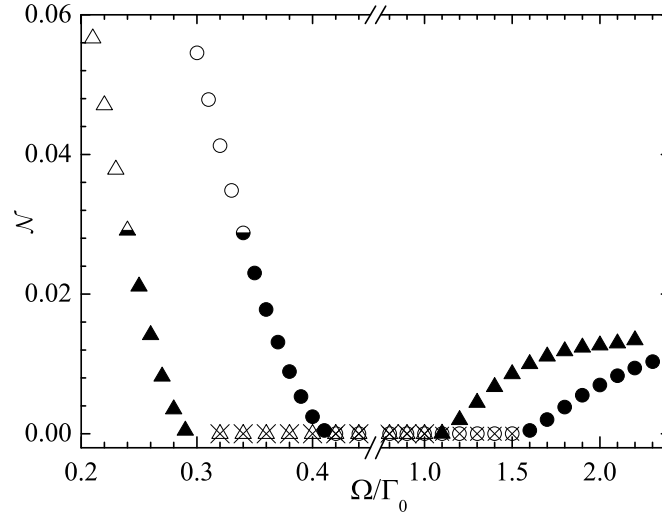

Fig. 6. The non-Markovianity \mathcal{N} as a function of the coupling constant $\Omega/\Gamma_0 = (\Omega_n/\Gamma_0, \forall n)$ between the cavity m_0 and the identical secondary cavities m_n ($n = 1, 2, \dots, N$). The circles represent $N = 1$ and the triangles $N = 2$. The white (black) color stands for type I (type II) pattern of non-Markovian dynamics and the black-white color specifies the coexistence of these two types of patterns. The symbols with a cross denote $\mathcal{N} = 0$. The other parameters used are $\Omega_0/\Gamma_0 = 0.5$ and $\Gamma_n = \Gamma_0$ ($n = 1, 2$).

5. Conclusion

In conclusion, we have investigated the dynamics of a two-level system in a composite environment with two hierarchies. The first hierarchy just contains a sub-environment which is in turn coupled to the second hierarchy consisting of $N \geq 1$ other sub-environments. Each of the $N + 1$ sub-environment comprises a mode which is damped with a finite rate into an independent memoryless reservoir. To be concrete, we take a two-level atom as the system s , a lossy cavity with a mode m_0 as the first environmental hierarchy and N other lossy cavities with modes m_1, m_2, \dots, m_N , respectively, as the second environmental hierarchy. First we consider the weak s - m_0 coupling regime and show that the Markovian dynamics of the atom can become non-Markovian one in the presence of the second environmental hierarchy. The non-Markovianity is proportional to the size of the second environmental hierarchy (i.e., the number N of the secondary cavities m_1, m_2, \dots, m_N) as well as to the m_0 - m_n coupling strengths. Therefore, our results indicate that enlargement of the second environmental hierarchy size as well as ability of manipulation of coupling strengths between the first and the second environmental hierarchies provide efficient alternative strategies to trigger non-Markovian dynamics of the interested system. The non-Markovian dynamics pattern in this case is nevertheless different compared to the usual situation of strong s - m_0 coupling regime without the second environmental hierarchy. To understand the occurrence mechanism of this type non-Markovian dynamics, we examine the energy flux among the atom and the cavities $m_0, m_1, m_2, \dots, m_N$. It is found that the m_0 - m_n coupling can make the cavity m_0 decay to its ground state in a finite time, while at that moment the atom still has nonzero probability in its excited state. As time goes on this coupling allows the cavity m_0 to retrieve the lost energy stored in the cavities m_1, m_2, \dots, m_N and meanwhile to

transfer them to the atom, triggering the non-Markovian dynamics of the atom. We then consider the strong s - m_0 coupling regime. Although in the absence of any secondary cavities the atom already exhibits non-Markovian dynamics, in the presence of the second hierarchy cavities the dynamics patterns may be transformed by varying the m_0 - m_n coupling strengths. Since the features, such as the revival moments, are different with respect to different non-Markovian dynamics patterns, our results suggest a possible method to tailor an on-demand pattern for the non-Markovian dynamics which plays a key application.

Acknowledgments

In this work, Z.X.M. and Y.J.X. are supported by the National Natural Science Foundation (China) under Grants No. 11204156, No. 61178012, and No. 10947006, and the Promotive Research Fund for Excellent Young and Middle- Aged Scientists of Shandong Province (China) under Project No. BS2013DX034, while N.B.A. is funded by the National Foundation for Science and Technology Development (NAFOSTED, Vietnam) under Project No. 103.01-2014.02.