

Research Article

A New S_4 Flavor Symmetry in 3-3-1 Model with Neutral Fermions

V. V. Vien¹ and H. N. Long²

¹ Department of Physics, Tay Nguyen University, 567 Le Duan, Buon Ma Thuot, Vietnam

² Hoang Ngoc Long, Institute of Physics, VAST, P.O. Box 429, Bo Ho, Hanoi 10000, Vietnam

Correspondence should be addressed to H. N. Long; hnlong@iop.vast.ac.vn

Received 25 September 2013; Revised 29 January 2014; Accepted 30 January 2014; Published 2 April 2014

Academic Editor: Anastasios Petkou

Copyright © 2014 V. V. Vien and H. N. Long. This is an open access article distributed under the Creative Commons Attribution License, which permits unrestricted use, distribution, and reproduction in any medium, provided the original work is properly cited. The publication of this article was funded by SCOAP³.

A new S_4 flavor model based on $SU(3)_C \otimes SU(3)_L \otimes U(1)_X$ gauge symmetry responsible for fermion masses and mixings is constructed. The neutrinos get small masses from only an antisextet of $SU(3)_L$ which is in a doublet under S_4 . In this work, we assume the VEVs of the antisextet differ from each other under S_4 and the difference of these VEVs is regarded as a small perturbation, and then the model can fit the experimental data on neutrino masses and mixings. Our results show that the neutrino masses are naturally small and a deviation from the tribimaximal neutrino mixing form can be realized. The quark masses and mixing matrix are also discussed. The number of required Higgs multiplets is less and the scalar potential of the model is simpler than those of the model based on S_3 and our previous S_4 model. The assignation of VEVs to antisextet leads to the mixing of the new gauge bosons and those in the standard model. The mixing in the charged gauge bosons as well as the neutral gauge bosons is considered.

1. Introduction

The experiments on neutrino oscillation confirm that neutrinos are massive particles [1–6]. The parameters of neutrino oscillations such as the squared mass differences and mixing angles are now well constrained. The data in PDG2012 [7–11] imply

$$\begin{aligned} \sin^2(2\theta_{12}) &= 0.857 \pm 0.024 \quad (t_{12} \approx 0.6717), \\ \sin^2(2\theta_{13}) &= 0.098 \pm 0.013 \quad (s_{13} \approx 0.1585), \\ \sin^2(2\theta_{23}) &> 0.95, \\ \Delta m_{21}^2 &= (7.50 \pm 0.20) \times 10^{-5} \text{ eV}^2, \\ \Delta m_{32}^2 &= (2.32_{-0.08}^{+0.12}) \times 10^{-3} \text{ eV}^2. \end{aligned} \quad (1)$$

These large neutrino mixing angles are completely different from the quark mixing ones defined by the CKM matrix [12, 13]. This has stimulated work on flavor symmetries and non-Abelian discrete symmetries are considered to be the most attractive candidate to formulate dynamical principles that can lead to the flavor mixing patterns for quarks and

lepton. There are many recent models based on the non-Abelian discrete symmetries, such as A_4 [14–29], S_3 [30–65], and S_4 [66–93].

An alternative to extend the standard model (SM) is the 3-3-1 models, in which the SM gauge group $SU(2)_L \otimes U(1)_Y$ is extended to $SU(3)_L \otimes U(1)_X$ which is investigated in [94–109]. The extension of the gauge group with respect to SM leads to interesting consequences. The first one is that the requirement of anomaly cancelation together with that of asymptotic freedom of QCD implies that the number of generations must necessarily be equal to the number of colors, hence giving an explanation for the existence of three generations. Furthermore, quark generations should transform differently under the action of $SU(3)_L$. In particular, two quark generations should transform as triplets, one as an antitriplet.

A fundamental relation holds among some of the generators of the group:

$$Q = T_3 + \beta T_8 + X, \quad (2)$$

where Q indicates the electric charge, T_3 and T_8 are two of the $SU(3)$ generators, and X is the generator of $U(1)_X$. β is

a key parameter that defines a specific variant of the model. The model thus provides a partial explanation for the family number, as also required by flavor symmetries such as S_4 for 3-dimensional representations. In addition, due to the anomaly cancellation one family of quarks has to transform under $SU(3)_L$ differently from the two others. S_4 can meet this requirement with the representations $\underline{1}$ and $\underline{2}$.

There are two typical variants of the 3-3-1 models as far as lepton sectors are concerned. In the minimal version, three $SU(3)_L$ lepton triplets are (ν_L, l_L, l_R^c) , where l_R are ordinary right-handed charged leptons [94–98]. In the second version, the third components of lepton triplets are the right-handed neutrinos, (ν_L, l_L, ν_R^c) [99–105]. To have a model with the realistic neutrino mixing matrix, we should consider another variant of the form (ν_L, l_L, N_R^c) where N_R are three new fermion singlets under SM symmetry with vanishing lepton numbers [110–113].

In our previous works we have also extended the above application to the 3-3-1 models [110–113]. In [112] we have studied the 3-3-1 model with neutral fermions based on S_4 group, in which most of the Higgs multiplets are in triplets under S_4 except that χ is in a singlet, and the exact tribimaximal form [114–117] is obtained, in which $\theta_{13} = 0$. As we know, the recent considerations have implied $\theta_{13} \neq 0$, but small as given in (1). This problem has been improved in [111] by adding a new triplet ρ and another antisextet s' , in which s' is regarded as a small perturbation. Therefore the model contains up to eight Higgs multiplets, and the scalar potential of the model is quite complicated.

In this paper, we propose another choice of fermion content and Higgs sector. As a consequence, the number of required Higgs is fewer and the scalar potential of the model is much simpler. The resulting model is near that of our previous work in [111] and includes those given in [112] as a special case and the physics is also different from the former. With the similar analysis as in [111], S_4 contains two triplets irreducible representation, one doublet and two singlets. This feature is useful to separate the third family of fermions from the others which contains a $\underline{2}$ irreducible representation which can connect two maximally mixed generations. Besides the facilitating maximal mixing through $\underline{2}$, it provides two inequivalent singlet representations $\underline{1}$ and $\underline{1}'$ which play a crucial role in consistently reproducing fermion masses and mixing as a perturbation. We have pointed out that this model is simpler than that of S_3 and our previous S_4 model, since fewer Higgs multiplets are needed in order to allow the fermions to gain masses and to break the gauge symmetry. Indeed, the model contains only six Higgs multiplets. On the other hand, the neutrino sector is simpler than those of S_3 and S_4 models [111, 112].

The rest of this work is organized as follows. In Sections 2 and 3 we present the necessary elements of the 3-3-1 model with S_4 flavor symmetry as in the above choice, as well as introducing necessary Higgs fields responsible for the charged-lepton masses. In Section 4, we discuss on quark sector. Section 5 is devoted to the neutrino mass and mixing. In Section 6 we discuss the gauge boson pattern of the model. We summarize our results and make conclusions in Section 7. Appendix A is devoted to the Higgs potential and

minimization conditions. Appendix B is devoted to S_4 group with its Clebsch-Gordan coefficients. Appendix C presents the lepton numbers and lepton parities of model particles.

2. Fermion Content

The gauge symmetry is based on $SU(3)_C \otimes SU(3)_L \otimes U(1)_X$, where the electroweak factor $SU(3)_L \otimes U(1)_X$ is extended from those of the SM whereas the strong interaction sector is retained. Each lepton family includes a new fermion singlet carrying no lepton number (N_R) arranged under the $SU(3)_L$ symmetry as a triplet (ν_L, l_L, N_R^c) and a singlet l_R . The residual electric charge operator Q is therefore related to the generators of the gauge symmetry by [110–112]

$$Q = T_3 - \frac{1}{\sqrt{3}}T_8 + X, \quad (3)$$

where T_a ($a = 1, 2, \dots, 8$) are $SU(3)_L$ charges with $\text{Tr } T_a T_b = (1/2)\delta_{ab}$ and X is the $U(1)_X$ charge. This means that the model under consideration does not contain exotic electric charges in the fundamental fermion, scalar, and adjoint gauge boson representations.

The particles in the lepton triplet have different lepton numbers (1 and 0), so the lepton number in the model does not commute with the gauge symmetry unlike the SM. Therefore, it is better to work with a new conserved charge \mathcal{L} commuting with the gauge symmetry and related to the ordinary lepton number by diagonal matrices [110–112, 118]

$$L = \frac{2}{\sqrt{3}}T_8 + \mathcal{L}. \quad (4)$$

The lepton charge arranged in this way (i.e., $L(N_R) = 0$ as assumed) is in order to prevent unwanted interactions due to $U(1)_{\mathcal{L}}$ symmetry and breaking (due to the lepton parity as shown below), such as the SM and exotic quarks, and to obtain the consistent neutrino mixing.

By this embedding, exotic quarks U and D as well as new non-Hermitian gauge bosons X^0 and Y^\pm possess lepton charges as of the ordinary leptons: $L(D) = -L(U) = L(X^0) = L(Y^-) = 1$. The lepton parity is introduced as follows: $P_l = (-)^L$, which is a residual symmetry of L . The particles possess $L = 0, \pm 2$ such as N_R , ordinary quarks, and bileptons having $P_l = 1$; the particles with $L = \pm 1$ such as ordinary leptons and exotic quarks having $P_l = -1$. Any nonzero VEV with odd parity, $P_l = -1$, will break this symmetry spontaneously [112]. For convenience in reading, the numbers L and P_l of the component particles are given in Appendix C.

In this paper we work on a basis where $\underline{3}$ and $\underline{3}'$ are real representations whereas the two-dimensional representation $\underline{2}$ of S_4 is complex, $\underline{2}^*(1^*, 2^*) = \underline{2}(2^*, 1^*)$, and

$$\underline{2} \otimes \underline{2} = \underline{1}(12 + 21) \oplus \underline{1}'(12 - 21) \oplus \underline{2}(22, 11). \quad (5)$$

The lepton content of this model is similar to that of [111] but is different from the one in [112]; namely, in [112] three left-handed leptons are put in one triplet $\underline{3}$ under S_4 , whereas in this model we put the first family of leptons in singlets $\underline{1}$ of S_4 , while the two other families are in the doublets $\underline{2}$. In the quark content, the third family is put in a singlet $\underline{1}$

and the two others in a doublet $\underline{2}$ under S_4 which satisfy the anomaly cancelation in 3-3-1 models. The difference in fermion content leads to the difference between this work and our previous work [112] in physical phenomenon as seen below. Under the $[SU(3)_L, U(1)_X, U(1)_{\mathcal{G}}, \underline{S}_4]$ symmetries as proposed, the fermions of the model transform as follows:

$$\begin{aligned}
\psi_{1L} &= (\nu_{1L}, l_{1L}, N_{1R}^c)^T \sim \left[3, -\frac{1}{3}, \frac{2}{3}, \underline{1}\right], \\
l_{1R} &\sim [1, -1, 1, \underline{1}], \\
\psi_{\alpha L} &= (\nu_{\alpha L}, l_{\alpha L}, N_{\alpha R}^c)^T \sim \left[3, -\frac{1}{3}, \frac{2}{3}, \underline{2}\right], \\
l_{\alpha R} &\sim [1, -1, 1, \underline{2}], \quad (\alpha = 2, 3), \\
Q_{3L} &= (u_{3L}, d_{3L}, U_L)^T \sim \left[3, \frac{1}{3}, -\frac{1}{3}, \underline{1}\right], \\
u_{3R} &\sim \left[1, \frac{2}{3}, 0, \underline{1}\right], \quad d_{3R} \sim \left[1, -\frac{1}{3}, 0, \underline{1}\right], \\
U_R &\sim \left[1, \frac{2}{3}, -1, \underline{1}\right], \\
Q_{iL} &= (d_{iL}, -u_{iL}, D_{iL})^T \sim \left[3^*, 0, \frac{1}{3}, \underline{2}\right], \quad (i = 1, 2), \\
d_{iR} &\sim \left[1, -\frac{1}{3}, 0, \underline{2}\right], \quad u_{iR} \sim \left[1, \frac{2}{3}, 0, \underline{2}\right], \\
D_{iR} &\sim \left[1, -\frac{1}{3}, 1, \underline{2}\right],
\end{aligned} \tag{6}$$

where the subscript numbers on field indicate respective families in order to define components of their S_4 multiplets. In the following, we consider possibilities of generating masses for the fermions. The scalar multiplets needed for this purpose would be introduced accordingly.

3. Charged Lepton Mass

In [112], both three families of left-handed fermions and three right-handed quarks are put in a triplet under S_4 . To generate masses for the charged leptons, we have introduced two $SU(3)_L$ scalar triplets ϕ and ϕ' lying in $\underline{3}$ and $\underline{3}'$ under S_4 , respectively, with VEVs $\langle\phi\rangle = (\nu \ \nu \ \nu)^T$ and $\langle\phi'\rangle = (\nu' \ \nu' \ \nu')^T$. From the invariant Yukawa interactions for the charged leptons, we obtain the right-handed charged leptons mixing matrices which are diagonal ones, $U_{lR} = 1$, and the right-handed one given by [112]

$$U_L = \frac{1}{\sqrt{3}} \begin{pmatrix} 1 & 1 & 1 \\ 1 & \omega & \omega^2 \\ 1 & \omega^2 & \omega \end{pmatrix}. \tag{7}$$

Similar to the charged lepton sector, to generate the quark masses, we have additionally introduced the three scalar Higgs triplets χ , η , η' lying in $\underline{1}$, $\underline{3}$, and $\underline{3}'$ under S_4 , respectively. Quark masses can be derived from the invariant Yukawa interactions for quarks with supposing that the VEVs of η , η' , and χ are (u, u, u) , (u', u', u') , and w , where $u = \langle\eta_1^0\rangle$,

$u' = \langle\eta_1'^0\rangle$, and $w = \langle\chi_3^0\rangle$. The other VEVs $\langle\eta_3^0\rangle$, $\langle\eta_3'^0\rangle$, and $\langle\chi_1^0\rangle$ vanish if the lepton parity is conserved. In addition, the VEV w also breaks the 3-3-1 gauge symmetry down to that of the standard model and provides the masses for the exotic quarks U and D as well as the new gauge bosons. The u , u' as well as ν , ν' break the SM symmetry and give the masses for the ordinary quarks, charged leptons, and gauge bosons. To keep consistency with the effective theory, we assume that w is much larger than those of ϕ and η [112]. The unitary matrices which couple the left-handed quarks u_L and d_L with those in the mass bases are unit ones ($U_L^u = 1$, $U_L^d = 1$), and the CKM quark mixing matrix at the tree level is then $U_{\text{CKM}} = U_{dL}^\dagger U_{uL} = 1$. For a detailed study on charged lepton and quark mass the reader can see [112].

In [112], to generate masses for neutrinos, we have introduced one $SU(3)_L$ antisextet lying in $\underline{1}$ under S_4 and one $SU(3)_L$ antisextet lying in $\underline{3}$ under S_4 with the VEV of s being set as $(\langle s_1 \rangle, 0, 0)$ under S_4 . The neutrino masses are explicitly separated and the lepton mixing matrix yields the exact tribimaximal form [112] where $\theta_{13} = 0$ which is a small deviation from recent neutrino oscillation data [7]. However, this problem will be improved in this work.

Because the fermion content of the model, as given in (6), is the same as that of one in [111] under all symmetries, so the charged-lepton mass is also similar to the one in [111]. Indeed, to generate masses for the charged leptons, we need two scalar triplets:

$$\begin{aligned}
\phi &= \begin{pmatrix} \phi_1^+ \\ \phi_2^0 \\ \phi_3^+ \end{pmatrix} \sim \left[3, \frac{2}{3}, -\frac{1}{3}, \underline{1}\right], \\
\phi' &= \begin{pmatrix} \phi_1'^+ \\ \phi_2'^0 \\ \phi_3'^+ \end{pmatrix} \sim \left[3, \frac{2}{3}, -\frac{1}{3}, \underline{1}'\right],
\end{aligned} \tag{8}$$

with VEVs $\langle\phi\rangle = (0, \nu, 0)^T$ and $\langle\phi'\rangle = (0, \nu', 0)^T$.

The Yukawa interactions are

$$\begin{aligned}
-\mathcal{L}_l &= h_1 (\bar{\psi}_{1L} \phi)_1 l_{1R} + h_2 (\bar{\psi}_{\alpha L} \phi)_2 l_{\alpha R} + h_3 (\bar{\psi}_{\alpha L} \phi')_2 l_{\alpha R} + h.c. \\
&= h_1 (\bar{\psi}_{1L} \phi)_1 l_{1R} + h_2 (\bar{\psi}_{2L} \phi l_{2R} + \bar{\psi}_{3L} \phi l_{3R}) \\
&\quad + h_3 (\bar{\psi}_{3L} \phi' l_{3R} - \bar{\psi}_{2L} \phi' l_{2R}) + h.c.
\end{aligned} \tag{9}$$

The mass Lagrangian of the charged leptons reads

$$\begin{aligned}
-\mathcal{L}_l^{\text{mass}} &= (\bar{l}_{1L}, \bar{l}_{2L}, \bar{l}_{3L}) M_l (l_{1R}, l_{2R}, l_{3R})^T + h.c. \\
M_l &= \begin{pmatrix} h_1 \nu & 0 & 0 \\ 0 & h_2 \nu - h_3 \nu' & 0 \\ 0 & 0 & h_2 \nu + h_3 \nu' \end{pmatrix} \equiv \begin{pmatrix} m_e & 0 & 0 \\ 0 & m_\mu & 0 \\ 0 & 0 & m_\tau \end{pmatrix}.
\end{aligned} \tag{10}$$

It is then diagonalized, and

$$U_{eL}^+ = U_{eR} = I. \quad (11)$$

This means that the charged leptons $l_{1,2,3}$ by themselves are the physical mass eigenstates, and the lepton mixing matrix depends on only that of the neutrinos that will be studied in Section 5.

We see that the masses of muon and tauon are separated by the ϕ' triplet. This is the reason why we introduce ϕ' in addition to ϕ .

The charged lepton Yukawa couplings $h_{1,2,3}$ relate to their masses as follows:

$$\begin{aligned} h_1 v &= m_e, \\ 2h_2 v &= m_\tau + m_\mu, \\ 2h_3 v' &= m_\tau - m_\mu. \end{aligned} \quad (12)$$

The current mass values for the charged leptons at the weak scale are given by [7]

$$\begin{aligned} m_e &= 0.511 \text{ MeV}, & m_\mu &= 105.66 \text{ MeV}, \\ m_\tau &= 1776.82 \text{ MeV}. \end{aligned} \quad (13)$$

Thus, we get

$$\begin{aligned} h_1 v &= 0.511 \text{ MeV}, & h_2 v &= 941.24 \text{ MeV}, \\ h_3 v' &= 835.58 \text{ MeV}. \end{aligned} \quad (14)$$

It follows that if v' and v are of the same order of magnitude, $h_1 \ll h_2$ and $h_2 \sim h_3$. This result is similar to the case of the model based on S_3 group [111]. On the other hand, if we choose the VEV of ϕ as $v = 100 \text{ GeV}$, then $h_1 \sim 5 \times 10^{-6}$, $h_3 \sim h_2 \sim 10^{-4}$.

4. Quark Mass

To generate the quark masses with a minimal Higgs content, we additionally introduce the following scalar multiplets:

$$\begin{aligned} \chi &= (\chi_1^0, \chi_2^-, \chi_3^0)^T \sim \left[3, -\frac{1}{3}, \frac{2}{3}, \frac{1}{3} \right], \\ \eta &= (\eta_1^0, \eta_2^-, \eta_3^0)^T \sim \left[3, -\frac{1}{3}, -\frac{1}{3}, \frac{1}{3} \right], \\ \eta' &= (\eta_1^0, \eta_2^-, \eta_3^0)^T \sim \left[3, -\frac{1}{3}, -\frac{1}{3}, \frac{1}{3} \right]. \end{aligned} \quad (15)$$

It is noticed that these scalars do not couple with the lepton sector due to the gauge invariance. The Yukawa interactions are then

$$\begin{aligned} -\mathcal{L}_q &= f_3 \bar{Q}_{3L} \chi U_R + f (\bar{Q}_{iL} \chi^*)_{\underline{2}} D_{iR} \\ &+ h_3^u \bar{Q}_{3L} \eta u_{3R} + h^u (\bar{Q}_{iL} \phi^*)_{\underline{2}} u_{iR} \\ &+ h'^u (\bar{Q}_{iL} \phi'^*)_{\underline{2}} u_{iR} + h_3^d \bar{Q}_{3L} \phi d_{3R} \end{aligned}$$

$$\begin{aligned} &+ h^d (\bar{Q}_{iL} \eta'^*)_{\underline{2}} d_{iR} + h^d (\bar{Q}_{iL} \eta'^*)_{\underline{2}} d_{iR} + h.c \\ &= f_3 \bar{Q}_{3L} \chi U_R + f \bar{Q}_{iL} \chi^* D_{iR} + h_3^u \bar{Q}_{3L} \eta u_{3R} \\ &+ h^u (\bar{Q}_{iL} \phi^* u_{iR} + \bar{Q}_{2L} \phi^* u_{2R}) \\ &+ h'^u (\bar{Q}_{2L} \phi'^* u_{2R} - \bar{Q}_{1L} \phi'^* u_{1R}) \\ &+ h_3^d \bar{Q}_{3L} \phi d_{3R} + h^d (\bar{Q}_{iL} \eta'^* d_{iR} + \bar{Q}_{2L} \eta'^* d_{2R}) \\ &+ h^d (\bar{Q}_{2L} \eta'^* d_{2R} - \bar{Q}_{1L} \eta'^* d_{1R}) + h.c. \end{aligned} \quad (16)$$

Suppose that the VEVs of η , η' , and χ are u , u' , and w , where $u = \langle \eta_1^0 \rangle$, $u' = \langle \eta_1'^0 \rangle$, and $w = \langle \chi_3^0 \rangle$. The other VEVs $\langle \eta_3^0 \rangle$, $\langle \eta_3'^0 \rangle$, and $\langle \chi_1^0 \rangle$ vanish due to the lepton parity conservation [111]. The exotic quarks therefore get masses $m_U = f_3 w$ and $m_{D_{1,2}} = f w$. In addition, w has to be much larger than those of ϕ , ϕ' , η , and η' for a consistency with the effective theory. The mass matrices for ordinary up-quarks and down-quarks are, respectively, obtained as follows:

$$\begin{aligned} M_u &= \begin{pmatrix} h^u v - h'^u v' & 0 & 0 \\ 0 & h^u v + h'^u v' & 0 \\ 0 & 0 & h_3^u u \end{pmatrix} \\ &\equiv \begin{pmatrix} m_u & 0 & 0 \\ 0 & m_c & 0 \\ 0 & 0 & m_t \end{pmatrix}, \\ M_d &= \begin{pmatrix} h^d u - h'^d u' & 0 & 0 \\ 0 & h^d u + h'^d u' & 0 \\ 0 & 0 & h_3^d v \end{pmatrix} \\ &\equiv \begin{pmatrix} m_d & 0 & 0 \\ 0 & m_s & 0 \\ 0 & 0 & m_b \end{pmatrix}. \end{aligned} \quad (17)$$

Similar to the charged leptons, the masses of $u - c$ and $d - s$ quarks are in pair separated by the scalars ϕ' and η' , respectively. We see also that the introduction of η' in addition to η is necessary to provide the different masses for u and c quarks as well as for d and s quarks.

The expressions (17) yield the relations:

$$\begin{aligned} h_3^u u &= m_t, & 2h^u v &= m_u + m_c, & 2h'^u v' &= m_c - m_u, \\ h_3^d v &= m_b, & 2h^d u &= m_d + m_s, & 2h'^d u' &= m_s - m_d. \end{aligned} \quad (18)$$

The current mass values for the quarks are given by [7]

$$\begin{aligned} m_u &= (1.8 \div 3.0) \text{ MeV}, & m_d &= (4.5 \div 5.5) \text{ MeV}, \\ m_c &= (1.25 \div 1.30) \text{ GeV}, \\ m_s &= (90.0 \div 100.0) \text{ MeV}, & m_t &= (172.1 \div 174.9) \text{ GeV}, \\ m_b &= (4.13 \div 4.37) \text{ GeV}. \end{aligned} \quad (19)$$

Hence

$$\begin{aligned}
h_3^u u &= (172.1 \div 174.9) \text{ GeV}, & h_3^d v &= (4.13 \div 4.37) \text{ GeV}, \\
h^u v &= (625.9 \div 651.5) \text{ MeV}, \\
h^d u &= (47.25 \div 52.75) \text{ MeV}, \\
h^d u' &= (42.75 \div 47.25) \text{ MeV}, \\
h^u v' &= (624.1 \div 648.5) \text{ MeV}.
\end{aligned} \tag{20}$$

It is obvious that if $u \sim v \sim v' \sim u'$, the Yukawa coupling hierarchies are $h^u \sim h^u \ll h_3^u, h^d \sim h^d \ll h_3^d$, and the couplings between up-quarks (h^u, h^u, h_3^u) and Higgs scalar multiplets are slightly heavier than those of down-quarks (h^d, h^d, h_3^d), respectively.

The unitary matrices, which couple the left-handed up- and down-quarks with those in the mass bases, are $U_L^u = 1$ and $U_L^d = 1$, respectively. Therefore we get the CKM matrix

$$U_{\text{CKM}} = U_L^{d\dagger} U_L^u = 1. \tag{21}$$

This is a good approximation for the realistic quark mixing matrix, which implies that the mixings among the quarks are dynamically small. The small permutations such as a breaking of the lepton parity due to the VEVs $\langle \eta_3^0 \rangle$, $\langle \eta_3'^0 \rangle$, and $\langle \chi_1^0 \rangle$ or a violation of \mathcal{L} and/or S_4 symmetry due to unnormal Yukawa interactions, namely, $\bar{Q}_{3L} \chi u_{3R}$, $\bar{Q}_{iL} \chi^* d_{iR}$, $\bar{Q}_{3L} \chi u_{iR}$, $\bar{Q}_{iL} \chi^* d_{3R}$, and so forth, will disturb the tree level matrix resulting in mixing between ordinary and exotic quarks and possibly providing the desirable quark mixing pattern. A detailed study on these problems is out of the scope of this work and should be skipped.

5. Neutrino Mass and Mixing

The neutrino masses arise from the couplings of $\bar{\psi}_{\alpha L}^c \psi_{\alpha L}$, $\bar{\psi}_{1L}^c \psi_{1L}$, and $\bar{\psi}_1^c \psi_{\alpha L}$ to scalars, where $\bar{\psi}_{\alpha L}^c \psi_{\alpha L}$ transforms as $3^* \oplus 6$ under $SU(3)_L$ and $\underline{1} \oplus \underline{2} \oplus \underline{3} \oplus \underline{3}'$ under S_4 , $\bar{\psi}_{1L}^c \psi_{1L}$ transforms as $3^* \oplus 6$ under $SU(3)_L$ and $\underline{1}$ under S_4 , and $\bar{\psi}_1^c \psi_{\alpha L}$ transforms as $3^* \oplus 6$ under $SU(3)_L$ and $\underline{2}$ under S_4 . For the known scalar triplets $(\phi, \phi', \chi, \eta, \eta')$, only available interactions are $(\bar{\psi}_{\alpha L}^c \psi_{\alpha L})\phi$ and $(\bar{\psi}_{\alpha L}^c \psi_{\alpha L})\phi'$ but explicitly suppressed because of the \mathcal{L} -symmetry. We will therefore propose new $SU(3)_L$ antisextets instead of coupling to $\bar{\psi}_L^c \psi_L$ responsible for the neutrino masses which are lying in either $\underline{1}$, $\underline{2}$, $\underline{3}$, or $\underline{3}'$ under S_4 . In [112], we have introduced two $SU(3)_L$ antisextets σ, s which are lying in $\underline{1}$ and $\underline{3}$ under S_4 , respectively. Contrastingly, in this work, with fermion content as proposed, to obtain a realistic neutrino spectrum, the model needs only one antisextet which transforms as follows:

$$s_i = \begin{pmatrix} s_{11}^0 & s_{12}^+ & s_{13}^0 \\ s_{12}^+ & s_{22}^+ & s_{23}^0 \\ s_{13}^0 & s_{23}^+ & s_{33}^0 \end{pmatrix} \sim \left[6^*, \frac{2}{3}, -\frac{4}{3}, \underline{2} \right], \tag{22}$$

where the numbered subscripts on the component scalars are the $SU(3)_L$ indices, whereas $i = 1, 2$ is that of S_4 . The VEV of s is set as $(\langle s_1 \rangle, \langle s_2 \rangle)$ under S_4 , in which

$$\langle s_i \rangle = \begin{pmatrix} \lambda_i & 0 & v_i \\ 0 & 0 & 0 \\ v_i & 0 & \Lambda_i \end{pmatrix}. \quad (i = 1, 2). \tag{23}$$

Following the potential minimization conditions, we have several VEV alignments. The first is that $\langle s_1 \rangle = \langle s_2 \rangle$ and then S_4 is broken into an eight-element subgroup, which is isomorphic to D_4 . The second is that $\langle s_1 \rangle \neq 0 = \langle s_2 \rangle$ or $\langle s_1 \rangle = 0 \neq \langle s_2 \rangle$ and then S_4 is broken into A_4 consisting of the identity and the even permutations of four objects. The third is that $\langle s_1 \rangle \neq \langle s_2 \rangle \neq 0$ and then S_4 is broken into a four-element subgroup consisting of the identity and three double transitions, which is isomorphic to Klein four group [75] (in this paper we denote this group by K_4). To obtain a realistic neutrino spectrum, we argue that both the breakings $S_4 \rightarrow D_4$ and $S_4 \rightarrow K_4$ must take place. We therefore assume that its VEVs are aligned as the former to derive the direction of the breaking $S_4 \rightarrow D_4$, and this happens in any case bellow:

$$\begin{aligned}
\lambda_1 = \lambda_2 \equiv \lambda_s, & \quad v_1 = v_2 \equiv v_s, & \quad \Lambda_1 = \Lambda_2 \equiv \Lambda_s, \\
\langle s_1 \rangle = \langle s_2 \rangle = \langle s \rangle = \begin{pmatrix} \lambda_s & 0 & v_s \\ 0 & 0 & 0 \\ v_s & 0 & \Lambda_s \end{pmatrix}.
\end{aligned} \tag{24}$$

The direction of the breaking $S_4 \rightarrow K_4$ is equivalent to the breaking $D_4 \rightarrow \{\text{Identity}\}$. In this direction, we set $\langle s_1 \rangle = \langle s \rangle \neq \langle s_2 \rangle \neq 0$. If D_4 is unbroken, we have $\langle s_1 \rangle = \langle s_2 \rangle = \langle s \rangle$ as in (24), and on the contrary, if D_4 is unbroken, we have $\langle s \rangle = \langle s_2 \rangle \approx \langle s_1 \rangle$:

$$\langle s_1 \rangle = \begin{pmatrix} \lambda_1 & 0 & v_1 \\ 0 & 0 & 0 \\ v_1 & 0 & \Lambda_1 \end{pmatrix}. \tag{25}$$

The difference between $\langle s_1 \rangle$ and $\langle s_2 \rangle$ is very small which is regarded as a small perturbation as considered bellow. It is noteworthy that the derivation in this paper contains a fewer, in comparison with the model based on the S_3 group [111], number of Higgs triplets; consequently the Higgs sector and the minimization condition of the potential are much simpler. Moreover, the obtained model, despite the compact in Higgs sector, can fit the current data with $\theta_{13} \neq 0$, while the old version [112] based on S_4 cannot provide nonvanishing θ_{13} .

In general, the Yukawa interactions are

$$\begin{aligned}
-\mathcal{L}_\nu &= \frac{1}{2} x (\bar{\psi}_{1L}^c \psi_L)_2 s_i + \frac{1}{2} y (\bar{\psi}_L^c \psi_L)_2 s_i + h.c \\
&= \frac{1}{2} x (\bar{\psi}_{1L}^c \psi_{2L} s_2 + \bar{\psi}_{1L}^c \psi_{3L} s_1) \\
&\quad + \frac{1}{2} y (\bar{\psi}_{2L}^c \psi_{2L} s_1 + \bar{\psi}_{3L}^c \psi_{3L} s_2) + h.c.
\end{aligned} \tag{26}$$

With the alignments of VEVs as in (24) and (25), the mass Lagrangian for the neutrinos is determined by

$$-\mathcal{L}_\nu^{\text{mass}} = \frac{1}{2} \bar{\chi}_L^c M_\nu \chi_L + h.c.,$$

$$\chi_L \equiv \begin{pmatrix} \nu_L \\ N_R^c \end{pmatrix}, \quad M_\nu \equiv \begin{pmatrix} M_L & M_D^T \\ M_D & M_R \end{pmatrix}, \quad (27)$$

where $\nu = (\nu_1, \nu_2, \nu_3)^T$ and $N = (N_1, N_2, N_3)^T$. The mass matrices are then obtained by

$$M_{L,R,D} = \begin{pmatrix} 0 & a_{L,R,D} & b_{L,R,D} \\ a_{L,R,D} & c_{L,R,D} & 0 \\ b_{L,R,D} & 0 & d_{L,R,D} \end{pmatrix}, \quad (28)$$

with

$$\begin{aligned} a_L &= \frac{x}{2} \lambda_s, & a_D &= \frac{x}{2} \nu_s, & a_R &= \frac{x}{2} \Lambda_s, \\ b_L &= \frac{x}{2} \lambda_1, & b_D &= \frac{x}{2} \nu_1, & b_R &= \frac{x}{2} \Lambda_1, \\ c_L &= y \lambda_1, & c_D &= y \nu_1, & c_R &= y \Lambda_1, \\ d_L &= y \lambda_s, & d_D &= y \nu_s, & d_R &= y \Lambda_s. \end{aligned} \quad (29)$$

The VEVs $\Lambda_{1,2}$ break the 3-3-1 gauge symmetry down to that of the SM and provide the masses for the neutral fermions N_R and the new gauge bosons: the neutral Z' and the charged Y^\pm and $X^{0,*}$. The $\lambda_{1,2}$ and $\nu_{1,2}$ belong to the second stage of the symmetry breaking from the SM down to the $SU(3)_C \otimes U(1)_Q$ symmetry and contribute the masses to the neutrinos. Hence, to keep a consistency we assume that $\Lambda_{1,s} \gg \nu_{1,s} \gg \lambda_{1,s}$ [105].

Three active neutrinos therefore gain masses via a combination of type I and type II seesaw mechanisms derived from (27) and (28) as

$$M_{\text{eff}} = M_L - M_D^T M_R^{-1} M_D = \begin{pmatrix} A & B_1 & B_2 \\ B_1 & C_1 & D \\ B_2 & D & C_2 \end{pmatrix}, \quad (30)$$

where

$$\begin{aligned} A &= -\frac{(a_R b_D - a_D b_R)^2}{b_R^2 c_R + a_R^2 d_R}, \\ B_1 &= (b_R [a_R b_D c_D + a_L b_R c_R - a_D (b_R c_D + b_D c_R)] \\ &\quad + a_R (a_L a_R - a_D^2) d_R) \\ &\quad \times (b_R^2 c_R + a_R^2 d_R)^{-1}, \end{aligned}$$

$$\begin{aligned} B_2 &= (-b_D^2 b_R c_R + b_L b_R^2 c_R + a_D a_R b_R d_D + a_R^2 b_L d_R \\ &\quad - a_R b_D (a_R d_D + a_D d_R)) \\ &\quad \times (b_R^2 c_R + a_R^2 d_R)^{-1}, \\ C_1 &= \frac{b_R^2 (c_L c_R - c_D^2) + (a_R^2 c_L + a_D^2 c_R - 2a_D a_R c_D) d_R}{b_R^2 c_R + a_R^2 d_R}, \\ C_2 &= \frac{-2b_D b_R c_R d_D + b_R^2 c_R d_L + b_D^2 c_R d_R + a_R^2 (d_L d_R - d_D^2)}{b_R^2 c_R + a_R^2 d_R}, \\ D &= \frac{(a_R c_D - a_D c_R) (b_R d_D - b_D d_R)}{b_R^2 c_R + a_R^2 d_R}. \end{aligned} \quad (31)$$

The following comments of S_4 breaking are in order.

- (i) If S_4 is broken into D_4 (D_4 is unbroken), we have $A = D = 0$, $B_1 = B_2 = B$, and $C_1 = C_2 = C$, which is presented in Section 5.1.
- (ii) If S_4 is broken into K_4 (D_4 is broken into {Identity}), we have $A \approx 0$, $B_1 \approx B_2$, $C_1 \approx C_2$, and $D \neq 0$ but it is very small. In this case the disparity of two VEVs of $\langle s \rangle$ is regarded as a small perturbation as shown in Section 5.2.

We next divide our considerations into two cases to fit the data: the first case is $S_4 \rightarrow D_4$, and the second one is $S_4 \rightarrow K_4$.

5.1. Experimental Constraints in the Case $S_4 \rightarrow D_4$. If S_4 is broken into D_4 , $\lambda_1 = \lambda_2 \equiv \lambda_s$, $\nu_1 = \nu_2 \equiv \nu_s$, $\Lambda_1 = \Lambda_2 \equiv \Lambda_s$, we have $A = 0$, $B_1 = B_2 \equiv B$, $C_1 = C_2 \equiv C$, and $D = 0$, and M_{eff} reduces to

$$M_{\text{eff}} = \begin{pmatrix} 0 & B & B \\ B & C & 0 \\ B & 0 & C \end{pmatrix}, \quad (32)$$

where

$$B = \left(\lambda_s - \frac{\nu_s^2}{\Lambda_s} \right) \frac{x}{2}, \quad C = \left(\lambda_s - \frac{\nu_s^2}{\Lambda_s} \right) y. \quad (33)$$

We can diagonalize the matrix M_{eff} in (32) as follows:

$$U^T M_{\text{eff}} U = \text{diag}(m_1, m_2, m_3), \quad (34)$$

where

$$\begin{aligned} m_1 &= \frac{1}{2} (C - \sqrt{C^2 + 8B^2}) = \left(\lambda_s - \frac{\nu_s^2}{\Lambda_s} \right) \frac{y + \sqrt{y^2 + 2x^2}}{2}, \\ m_2 &= \frac{1}{2} (C + \sqrt{C^2 + 8B^2}) = \left(\lambda_s - \frac{\nu_s^2}{\Lambda_s} \right) \frac{y - \sqrt{y^2 + 2x^2}}{2}, \\ m_3 &= C = \left(\lambda_s - \frac{\nu_s^2}{\Lambda_s} \right) y, \end{aligned} \quad (35)$$

and the neutrino mixing matrix takes the form:

$$U_0 = \begin{pmatrix} \frac{|K|}{\sqrt{|K|^2+2}} & -\frac{\sqrt{2}}{\sqrt{|K|^2+2}} & 0 \\ \frac{1}{\sqrt{|K|^2+2}} & \frac{1}{\sqrt{2}} \frac{|K|}{\sqrt{|K|^2+2}} & -\frac{1}{\sqrt{2}} \\ \frac{1}{\sqrt{|K|^2+2}} & \frac{1}{\sqrt{2}} \frac{|K|}{\sqrt{|K|^2+2}} & \frac{1}{\sqrt{2}} \end{pmatrix} \quad (36)$$

$$K = -\frac{C + \sqrt{C^2 + 8B^2}}{2B}.$$

Note that $m_1 m_2 = -2B^2$. This matrix can be parameterized in three Euler's angles, which implies

$$\theta_{13} = 0, \quad \theta_{23} = \frac{\pi}{4}, \quad \tan \theta_{12} = \frac{\sqrt{2}}{|K|}. \quad (37)$$

This case coincides with the data since $\sin^2(2\theta_{13}) < 0.15$ and $\sin^2(2\theta_{23}) > 0.92$ [119, 120]. For the remaining constraints, taking the central values from the data in [119]

$$\sin^2(2\theta_{12}) \approx 0.87, \quad (s_{12}^2 = 0.32),$$

$$\Delta m_{21}^2 = 7.59 \times 10^{-5} \text{ eV}^2, \quad \Delta m_{32}^2 = 2.43 \times 10^{-3} \text{ eV}^2, \quad (38)$$

and we have a solution

$$m_1 = 0.0280284 \text{ eV}, \quad m_2 = 0.0293347 \text{ eV},$$

$$m_3 = 0.0573631 \text{ eV}, \quad (39)$$

and $B = -0.0202757i \text{ eV}$, $C = 0.0573631 \text{ eV}$, $K = 1.44667$, and $|x/y| = 0.707087$. It follows that $\tan \theta_{12} = 0.977565$, ($\theta_{12} \approx 44.35^\circ$), and the neutrino mixing matrix form is very close to that of bimaximal mixing which takes the form:

$$U = \begin{pmatrix} 0.715083 & -0.69904 & 0 \\ 0.494296 & 0.50564 & -\frac{1}{\sqrt{2}} \\ 0.494296 & 0.50564 & \frac{1}{\sqrt{2}} \end{pmatrix}. \quad (40)$$

Now, it is natural to choose $\lambda_s, v_s^2/\Lambda_s$ in eV order, and suppose that $\lambda_s > v_s^2/\Lambda_s$. Let us assume $\lambda_s - v_s^2/\Lambda_s = 0.1$, and we have then $x = 0.399403i$ and $y = -0.573631$.

This result is not obviously consistent with the recent data on neutrinos oscillation in which $\theta_{13} \neq 0$, but small as given in [7]. However, as we will see in Section 5.2, this situation will be improved if the direction of the breaking $S_4 \rightarrow K_4$ takes place. This means that, for the model under consideration, both the breakings $S_4 \rightarrow D_4$ and $S_4 \rightarrow K_4$ (instead of $D_4 \rightarrow \{\text{Identity}\}$) must take place in the neutrino sector.

5.2. Experimental Constraints in the Case $S_4 \rightarrow K_4$. In this case S_4 is broken into the Klein four group K_4 , $\lambda_1 \neq \lambda_2, v_1 \neq v_2$,

and $\Lambda_1 \neq \Lambda_2$, and the direct consequence is $A \approx 0, B_1 \approx B_2, C_1 \approx C_2$, and $D \neq 0$. The general neutrino mass matrix in (30) can be rewritten in the form:

$$M_{\text{eff}} = \begin{pmatrix} 0 & B & B \\ B & C & 0 \\ B & 0 & C \end{pmatrix} + \begin{pmatrix} a^2 r & ap & aq \\ ap & q & r \\ aq & r & p \end{pmatrix}, \quad \left(a = \frac{x}{2y} \right)$$

$$= \begin{pmatrix} 0 & B & B \\ B & C & 0 \\ B & 0 & C \end{pmatrix} + \begin{pmatrix} a^2 r & 0 & 0 \\ 0 & 0 & r \\ 0 & r & 0 \end{pmatrix} \quad (41)$$

$$+ \begin{pmatrix} 0 & ap & 0 \\ ap & 0 & 0 \\ 0 & 0 & p \end{pmatrix} + \begin{pmatrix} 0 & 0 & aq \\ 0 & q & 0 \\ aq & 0 & 0 \end{pmatrix},$$

where B and C are given by (33), accommodated in the first matrix, which is matched to the case of $S_4 \rightarrow D_4$. The three last matrices in (41) are a deviation from the contribution due to the disparity of $\langle s_1 \rangle$ and $\langle s_2 \rangle$, namely, $A = a^2 r, B_1 - B = ap, B_2 - B = aq, q = C_1 - C, p = C_2 - C$, and $r = D$, with the $A, B_{1,2}, C_{1,2}$, and D being defined in (5), which correspond to $S_4 \rightarrow K_4$.

Substituting (29) into (5) we get

$$q = \left(\left[\Lambda_s^4 \lambda_1 - \lambda_s \Lambda_s (\Lambda_s^3 + \Lambda_1^3) + \Lambda_s^2 \Lambda_1 v_s^2 + \Lambda_1^3 v_s^2 \right. \right. \\ \left. \left. + \Lambda_s^3 v_s (v_s - 2v_1) + \Lambda_s \Lambda_1^2 (\lambda_1 \Lambda_1 - v_1^2) \right] y \right) \\ \times \left(\Lambda_s (\Lambda_s^3 + \Lambda_1^3) \right)^{-1} \\ = (\lambda_1 - \lambda_s) y \\ + \left(\left[\frac{\Lambda_s}{\Lambda_1^2} v_s^2 + \frac{v_s^2}{\Lambda_s} + \frac{\Lambda_s^2}{\Lambda_1^3} v_s^2 \right. \right. \\ \left. \left. - 2 \frac{\Lambda_s^2}{\Lambda_1^3} v_s v_1 - \frac{v_1^2}{\Lambda_1} \right] y \right) \\ \times \left(1 + \left(\frac{\Lambda_s}{\Lambda_1} \right)^3 \right)^{-1}, \\ p = \frac{\Lambda_1 (\Lambda_1 v_s - \Lambda_s v_1)^2 y}{\Lambda_s (\Lambda_s^3 + \Lambda_1^3)} = \frac{\Lambda_s (v_s/\Lambda_s - v_1/\Lambda_1)^2 y}{1 + (\Lambda_s/\Lambda_1)^3}, \\ r = -\frac{(\Lambda_1 v_s - \Lambda_s v_1)^2 y}{\Lambda_1^3 + \Lambda_s^3} = \frac{\Lambda_s (\Lambda_s/\Lambda_1) (v_s/\Lambda_s - v_1/\Lambda_1)^2 y}{1 + (\Lambda_s/\Lambda_1)^3}. \quad (42)$$

Indeed, if $S_4 \rightarrow D_4$, the deviations p, q, r will vanish, therefore the mass matrix M_{eff} in (30) reduces to its first term coinciding with (32). The first term of (41) provides bimaximal mixing pattern, in which $\theta_{13} = 0$ as shown in Section 5.1. The other matrices proportional to p, q, r due to contribution from the disparity of $\langle s_1 \rangle$ and $\langle s_2 \rangle$ will take the role of perturbation for such a deviation of θ_{13} . So, in this work we consider the disparity of $\langle s_1 \rangle$ and $\langle s_2 \rangle$ as a small perturbation and terminating the theory at the first order.

Without loss of generality, we consider the case of breaking $S_4 \rightarrow K_4$, in which $\lambda_1 \neq \lambda_s$ whereas $\nu_1 = \nu_s$ and $\Lambda_1 = \Lambda_s$. It is then $p = r = 0$, $q = (\lambda_1 - \lambda_s)y \equiv \epsilon y$ with $\epsilon = \lambda_1 - \lambda_s$ being a small parameter. In this case, the matrix M_{eff} in (41) reduces to

$$M_{\text{eff}} = \begin{pmatrix} 0 & \frac{x}{2y}C & \frac{x}{2y}C \\ \frac{x}{2y}C & C & 0 \\ \frac{x}{2y}C & 0 & C \end{pmatrix} + \epsilon \begin{pmatrix} 0 & 0 & \frac{x}{2} \\ 0 & y & 0 \\ \frac{x}{2} & 0 & 0 \end{pmatrix} \quad (43)$$

$$\equiv M_{\text{eff}}^0 + \epsilon M^{(1)}.$$

At the first order of perturbation, the physical neutrino masses are obtained as

$$m'_1 = \lambda_1 = m_1 + \epsilon \left(\frac{Kx + y}{K^2 + 2} \right),$$

$$m'_2 = \lambda_2 = m_2 + \frac{\epsilon K(Ky - 2x)}{2(K^2 + 2)}, \quad m'_3 = \lambda_3 = m_3 + \epsilon \frac{y}{2}, \quad (44)$$

where $m_{1,2,3}$ are the mass values as of the case $S_4 \rightarrow D_4$ given by (39). For the corresponding perturbed eigenstates, we put

$$U \longrightarrow U' = U + \Delta U, \quad (45)$$

where U is defined by (36), and

$$\Delta U = \begin{pmatrix} \Delta U_{11} & \Delta U_{12} & \Delta U_{13} \\ \Delta U_{21} & \Delta U_{22} & \Delta U_{23} \\ \Delta U_{31} & \Delta U_{32} & \Delta U_{33} \end{pmatrix}, \quad (46)$$

with

$$\Delta U_{11} = -\epsilon \frac{(K^2 - 2)x + 2Ky}{2(K^2 + 2)^{3/2}(m_1 - m_2)},$$

$$\Delta U_{21} = -\epsilon \frac{(Kx - 2y)}{4\sqrt{K^2 + 2}(m_1 - m_3)} + \epsilon \frac{K[(K^2 - 2)x + 2Ky]}{4(K^2 + 2)^{3/2}(m_1 - m_2)},$$

$$\Delta U_{31} = \epsilon \frac{(Kx - 2y)}{4\sqrt{K^2 + 2}(m_1 - m_3)} + \epsilon \frac{K[(K^2 - 2)x + 2Ky]}{4(K^2 + 2)^{3/2}(m_1 - m_2)},$$

$$\Delta U_{12} = -\epsilon \frac{K[(K^2 - 2)x + 2Ky]}{2\sqrt{2}(K^2 + 2)^{3/2}(m_1 - m_2)},$$

$$\Delta U_{22} = \frac{\epsilon}{2\sqrt{2}} \frac{Ky + x}{\sqrt{K^2 + 2}(m_2 - m_3)} - \frac{\epsilon}{2\sqrt{2}} \frac{(K^2 - 2)x + 2Ky}{(K^2 + 2)^{3/2}(m_1 - m_2)},$$

$$\Delta U_{32} = -\frac{\epsilon}{2\sqrt{2}} \frac{Ky + x}{\sqrt{K^2 + 2}(m_2 - m_3)} - \frac{\epsilon}{2\sqrt{2}} \frac{(K^2 - 2)x + 2Ky}{(K^2 + 2)^{3/2}(m_1 - m_2)},$$

$$\Delta U_{13} = -\frac{\epsilon}{2\sqrt{2}} \frac{K(Kx - 2y)}{(K^2 + 2)(m_1 - m_3)} - \frac{\epsilon}{\sqrt{2}} \frac{Ky + x}{(K^2 + 2)(m_2 - m_3)},$$

$$\Delta U_{23} = \Delta U_{33} = -\frac{\epsilon}{2\sqrt{2}} \frac{Kx - 2y}{(K^2 + 2)(m_1 - m_3)} + \frac{\epsilon}{2\sqrt{2}} \frac{K(Ky + x)}{(K^2 + 2)(m_2 - m_3)}. \quad (47)$$

The lepton mixing matrix in this case U' can still be parameterized in three new Euler's angles θ'_{ij} , which are also a perturbation from the θ_{ij} in the case 1, defined by

$$s'_{13} = -U'_{13} = \Delta U_{13}$$

$$= -\frac{\epsilon}{2\sqrt{2}} \frac{K(Kx - 2y)}{(K^2 + 2)(m_1 - m_3)} - \frac{\epsilon}{\sqrt{2}} \frac{Ky + x}{(K^2 + 2)(m_2 - m_3)} = -\frac{\epsilon y}{2\sqrt{2}B},$$

$$t'_{12} = -\frac{U'_{12}}{U'_{11}}$$

$$= \left(- \left[4\epsilon B^2 Cx + \epsilon C^2 \left(C + \sqrt{C^2 + 8B^2} \right) x + 2BC \left(C + \sqrt{C^2 + 8B^2} \right) (2C - \epsilon y) + 8B^3 \left(4C + 4\sqrt{C^2 + 8B^2} - \epsilon y \right) \right] \right) \times \left(\left\{ \sqrt{2} \left[64B^4 + 2C^3 \left(C + \sqrt{C^2 + 8B^2} \right) - \epsilon BC \left(C + \sqrt{C^2 + 8B^2} \right) x + 2B^2 \left(12C^2 + 8C\sqrt{C^2 + 8B^2} \right) + \epsilon Cy + \epsilon y\sqrt{C^2 + 8B^2} \right] \right\} \right)^{-1},$$

$$t'_{23} = -\frac{U'_{23}}{U'_{33}} = \frac{4B^2 + \epsilon Bx - \epsilon Cy}{4B^2 - \epsilon Bx + \epsilon Cy}. \quad (48)$$

It is easily to show that our model is consistent since the five experimental constraints on the mixing angles and squared neutrino mass differences can be, respectively, fitted with two Yukawa coupling parameters x , y of the antisextet scalar s with the above mentioned VEVs. Indeed, taking the data in (1) we obtain $\epsilon \simeq 0.0692$, $x \simeq 0.0728$, $y \simeq -0.1562$, and $B \simeq -0.0241$ eV and $C = 0.022$ eV, $K = 1.943$, and $t'_{23} = 0.9045$ [$\theta'_{23} \simeq 42.13^\circ$, $\sin^2(2\theta'_{23}) = 0.98999$ satisfying the condition $\sin^2(2\theta'_{23}) > 0.95$]. The neutrino masses are explicitly given as $m'_1 \simeq -0.02737$ eV, $m'_2 \simeq -0.02870$ eV, and $m'_3 \simeq -0.05607$ eV. The neutrino mixing matrix then takes the form:

$$U = \begin{pmatrix} 0.8251 & -0.5657 & -0.1585 \\ 0.3302 & 0.6781 & -0.6716 \\ 0.4697 & 0.4888 & 0.7426 \end{pmatrix}. \quad (49)$$

$$\frac{g}{2} \begin{pmatrix} W_{\mu 3} + \frac{W_{\mu 8}}{\sqrt{3}} + t\sqrt{\frac{2}{3}}XB_{\mu} & \sqrt{2}W_{\mu}^{'+} & \sqrt{2}X_{\mu}^{i0}, \\ \sqrt{2}W_{\mu}^{i-} & -W_{\mu 3} + \frac{W_{\mu 8}}{\sqrt{3}} + t\sqrt{\frac{2}{3}}XB_{\mu} & \sqrt{2}Y_{\mu}^{i-} \\ \sqrt{2}X_{\mu}^{i0*} & \sqrt{2}Y_{\mu}^{i+} & -\frac{2}{\sqrt{3}}W_{\mu 8} + t\sqrt{\frac{2}{3}}XB_{\mu} \end{pmatrix}, \quad (52)$$

with $t = g_X/g$. We note that W_4 and W_5 are pure real and imaginary parts of X^0 and X^{0*} , respectively. The covariant derivative for an antisextet with the VEV part is [121]

$$D_{\mu} \langle s_i \rangle = \frac{ig}{2} \{W_{\mu}^a \lambda_a^* \langle s_i \rangle + \langle s_i \rangle W_{\mu}^a \lambda_a^{*T}\} - ig_X T_9 X B_{\mu} \langle s_i \rangle. \quad (53)$$

The covariant derivative (53) acting on the antisextet VEVs is given by

$$\begin{aligned} [D_{\mu} \langle s_i \rangle]_{11} &= ig \left(\lambda_i W_{\mu 3} + \frac{\lambda_i}{\sqrt{3}} W_{\mu 8} \right. \\ &\quad \left. + \sqrt{\frac{2}{3}} \frac{1}{3} t \lambda_i B_{\mu} + \sqrt{2} v_i X^{i0*} \right), \\ [D_{\mu} \langle s_i \rangle]_{12} &= \frac{ig}{\sqrt{2}} (\lambda_i W_{\mu}^{'+} + v_i Y_{\mu}^{i+}), \\ [D_{\mu} \langle s_i \rangle]_{13} &= \frac{ig}{2} \left(v_i W_{\mu 3} - \frac{v_i}{\sqrt{3}} W_{\mu 8} + \frac{2}{3} \sqrt{\frac{2}{3}} t v_i B_{\mu} \right. \\ &\quad \left. + \sqrt{2} \lambda_i X_{\mu}^{i0} + \sqrt{2} \Lambda_i X_{\mu}^{i0*} \right), \\ [D_{\mu} \langle s_i \rangle]_{21} &= [D_{\mu} \langle s_i \rangle]_{12}, \quad [D_{\mu} \langle s_i \rangle]_{22} = 0, \\ [D_{\mu} \langle s_i \rangle]_{23} &= \frac{ig}{\sqrt{2}} (v_i W_{\mu}^{i+} + \Lambda_i Y_{\mu}^{i+}), \end{aligned}$$

6. Gauge Bosons

The covariant derivative of a triplet is given by

$$D_{\mu} = \partial_{\mu} - ig \frac{\lambda_a}{2} W_{\mu a} - ig_X X \frac{\lambda_9}{2} B_{\mu} = \partial_{\mu} - iP_{\mu}, \quad (50)$$

where λ_a ($a = 1, 2, \dots, 8$) are Gell-Mann matrices, $\lambda_9 = \sqrt{2/3} \text{diag}(1, 1, 1)$, $\text{Tr} \lambda_a \lambda_b = 2\delta_{ab}$, $\text{Tr} \lambda_9 \lambda_9 = 2$, and X is X -charge of Higgs triplets.

Let us denote the following combinations:

$$\begin{aligned} W_{\mu}^{'+} &= \frac{W_{\mu 1} - iW_{\mu 2}}{\sqrt{2}}, & X_{\mu}^{i0} &= \frac{W_{\mu 4} - iW_{\mu 5}}{\sqrt{2}}, \\ Y_{\mu}^{i-} &= \frac{W_{\mu 6} - iW_{\mu 7}}{\sqrt{2}}, & W_{\mu}^{i-} &= (W_{\mu}^{'+})^*, & Y_{\mu}^{i+} &= (Y_{\mu}^{i-})^*, \end{aligned} \quad (51)$$

and then P_{μ} is rewritten in a convenient form as follows:

$$\begin{aligned} [D_{\mu} \langle s_i \rangle]_{31} &= [D_{\mu} \langle s_i \rangle]_{13}, & [D_{\mu} \langle s_i \rangle]_{32} &= [D_{\mu} \langle s_i \rangle]_{23}, \\ [D_{\mu} \langle s_i \rangle]_{33} &= ig \left(-\frac{2}{\sqrt{3}} \Lambda_i W_{\mu 8} + \sqrt{\frac{2}{3}} \frac{1}{3} t \Lambda_i B_{\mu} + \sqrt{2} v_i X_{\mu}^{i0} \right). \end{aligned} \quad (54)$$

The masses of gauge bosons in this model are defined as follows:

$$\begin{aligned} \mathcal{L}_{\text{mass}}^{\text{GB}} &= (D_{\mu} \langle \phi \rangle)^{\dagger} (D^{\mu} \langle \phi \rangle) + (D_{\mu} \langle \phi' \rangle)^{\dagger} (D^{\mu} \langle \phi' \rangle) \\ &\quad + (D_{\mu} \langle \chi \rangle)^{\dagger} (D^{\mu} \langle \chi \rangle) + (D_{\mu} \langle \eta \rangle)^{\dagger} (D^{\mu} \langle \eta \rangle) \\ &\quad + (D_{\mu} \langle \eta' \rangle)^{\dagger} (D^{\mu} \langle \eta' \rangle) + \text{Tr} [(D_{\mu} \langle s_1 \rangle)^{\dagger} (D^{\mu} \langle s_1 \rangle)] \\ &\quad + \text{Tr} [(D_{\mu} \langle s_2 \rangle)^{\dagger} (D^{\mu} \langle s_2 \rangle)], \end{aligned} \quad (55)$$

where $\mathcal{L}_{\text{mass}}^{\text{GB}}$ in (55) is different from the one in [122] by the difference of the components of the antisextet s . In [122], $\langle s_1 \rangle = \langle s_1 \rangle$, namely, $\lambda_1 = \lambda_2 = \lambda_s$, $v_1 = v_2 = v_s$, and $\Lambda_1 = \Lambda_2 = \Lambda_s$, are taken into account, and the contribution of perturbation has been skipped at the first order. In the following, we consider the general case in which $\lambda_1 \neq \lambda_2$, $v_1 \neq v_2$, and $\Lambda_1 \neq \Lambda_2$. As a consequence, the fewer number of

Higgs multiplets is needed in order to allow the fermions to gain masses and with the simpler scalar Higgs potential as mentioned above.

Substitution of the VEVs of Higgs multiplets into (55) yields

$$\begin{aligned}
\mathcal{L}_{\text{mass}}^{\text{GB}} &= \frac{v^2}{324} \left[81g^2 (W_{\mu 1}^2 + W_{\mu 2}^2) + 81g^2 (W_{\mu 6}^2 + W_{\mu 7}^2) \right. \\
&\quad \left. + (-9gW_{\mu 3} + 3\sqrt{3}gW_{\mu 8} + 2\sqrt{6}g_X B_\mu)^2 \right] \\
&+ \frac{v'^2}{324} \left[81g^2 (W_{\mu 1}^2 + W_{\mu 2}^2) + 81g^2 (W_{\mu 6}^2 + W_{\mu 7}^2) \right. \\
&\quad \left. + (-9gW_{\mu 3} + 3\sqrt{3}gW_{\mu 8} + 2\sqrt{6}g_X B_\mu)^2 \right] \\
&+ \frac{\omega^2}{108} \left[27g^2 (W_{\mu 4}^2 + W_{\mu 5}^2) + 27g^2 (W_{\mu 6}^2 + W_{\mu 7}^2) \right. \\
&\quad \left. + 36g^2 W_{\mu 8}^2 + 12\sqrt{2}gg_X W_{\mu 8} B_\mu + 2g_X^2 B_\mu^2 \right] \\
&+ \frac{u^2}{324} \left[81g^2 (W_{\mu 1}^2 + W_{\mu 2}^2) + 81g^2 (W_{\mu 4}^2 + W_{\mu 5}^2) \right. \\
&\quad \left. + (-9gW_{\mu 3} - 3\sqrt{3}gW_{\mu 8} + \sqrt{6}g_X B_\mu)^2 \right] \\
&+ \frac{u'^2}{324} \left[81g^2 (W_{\mu 1}^2 + W_{\mu 2}^2) + 81g^2 (W_{\mu 4}^2 + W_{\mu 5}^2) \right. \\
&\quad \left. + (-9gW_{\mu 3} - 3\sqrt{3}gW_{\mu 8} + \sqrt{6}g_X B_\mu)^2 \right] \\
&+ \frac{g^2}{6} \left[2(\Lambda_1 v_1 + \Lambda_2 v_2) (3W_{\mu 3} W_{\mu 4} + 3W_{\mu 1} W_{\mu 6} \right. \\
&\quad \left. - 3W_{\mu 2} W_{\mu 7} - 5\sqrt{3}W_{\mu 4} W_{\mu 8}) \right. \\
&\quad + 3(v_1^2 + v_2^2 + \lambda_1^2 + \lambda_2^2) W_{\mu 1}^2 \\
&\quad + 3(v_1^2 + v_2^2 + \lambda_1^2 + \lambda_2^2) W_{\mu 2}^2 \\
&\quad + 3(v_1^2 + v_2^2 + 2\lambda_1^2 + 2\lambda_2^2) W_{\mu 3}^2 \\
&\quad + 3(4v_1^2 + 4v_2^2 + \lambda_1^2 + \lambda_2^2 + \Lambda_1^2 + \Lambda_2^2 \\
&\quad \left. + 2\Lambda_1 \lambda_1 + 2\Lambda_2 \lambda_2) W_{\mu 4}^2 \right. \\
&\quad + 3(4v_1^2 + 4v_2^2 + \lambda_1^2 + \lambda_2^2 + \Lambda_1^2 + \Lambda_2^2 \\
&\quad \left. - 2\Lambda_1 \lambda_1 - 2\Lambda_2 \lambda_2) W_{\mu 5}^2 \right. \\
&\quad + 3(v_1^2 + v_2^2 + \Lambda_1^2 + \Lambda_2^2) W_{\mu 6}^2 \\
&\quad + 3(v_1^2 + v_2^2 + \Lambda_1^2 + \Lambda_2^2) W_{\mu 7}^2 \\
&\quad \left. + 2\sqrt{3}(-v_1^2 - v_2^2 + 2\lambda_1^2 + 2\lambda_2^2) W_{\mu 3} W_{\mu 8} \right]
\end{aligned}$$

$$\begin{aligned}
&+ (v_1^2 + v_2^2 + 2\lambda_1^2 + 2\lambda_2^2 + 8\Lambda_1^2 + 8\Lambda_2^2) W_{\mu 8}^2 \\
&+ 18(\lambda_1 v_1 + \lambda_2 v_2) W_{\mu 3} W_{\mu 4} \\
&+ 6(\lambda_1 v_1 + \lambda_2 v_2) W_{\mu 1} W_{\mu 6} \\
&- 6(\lambda_1 v_1 + \lambda_2 v_2) W_{\mu 2} W_{\mu 7} \\
&+ 2\sqrt{3}(\lambda_1 v_1 + \lambda_2 v_2) W_{\mu 4} W_{\mu 8} \\
&+ \frac{2}{27} t^2 g^2 (\lambda_1^2 + \lambda_2^2 + \Lambda_1^2 + \Lambda_2^2 + 2v_1^2 + 2v_2^2) B_\mu^2 \\
&- \frac{2}{3} \sqrt{\frac{2}{3}} t g^2 (\lambda_1^2 + \lambda_2^2 + v_1^2 + v_2^2) W_{\mu 3} B_\mu \\
&- \frac{4}{3} \sqrt{\frac{2}{3}} t g^2 [(\lambda_1 + \Lambda_1) v_1 + (\lambda_2 + \Lambda_2) v_2] W_{\mu 4} B_\mu \\
&- \frac{2\sqrt{2}}{9} t g^2 (\lambda_1^2 + \lambda_2^2 - v_1^2 - v_2^2 - 2\Lambda_1^2 - 2\Lambda_2^2) W_{\mu 8} B_\mu.
\end{aligned} \tag{56}$$

We can separate $\mathcal{L}_{\text{mass}}^{\text{GB}}$ in (57) into

$$\mathcal{L}_{\text{mass}}^{\text{GB}} = \mathcal{L}_{\text{mass}}^{W_5} + \mathcal{L}_{\text{mix}}^{\text{CGB}} + \mathcal{L}_{\text{mix}}^{\text{NGB}}, \tag{57}$$

where $\mathcal{L}_{\text{mass}}^{W_5}$ is the Lagrangian part of the imaginary part W_5 . This boson is decoupled with mass given by

$$\begin{aligned}
M_{W_5}^2 &= \frac{g^2}{2} (\omega^2 + u^2 + u'^2 + 8v_1^2 + 8v_2^2 + 2\lambda_1^2 + 2\lambda_2^2 \\
&\quad + 2\Lambda_1^2 + 2\Lambda_2^2 - 4\Lambda_1 \lambda_1 - 4\Lambda_2 \lambda_2).
\end{aligned} \tag{58}$$

In the limit $\lambda_1, \lambda_2, v_1, v_2 \rightarrow 0$ we have

$$M_{W_5}^2 = \frac{g^2}{2} (\omega^2 + u^2 + u'^2 + 2\Lambda_1^2 + 2\Lambda_2^2). \tag{59}$$

$\mathcal{L}_{\text{mix}}^{\text{CGB}}$ is the Lagrangian part of the charged gauge bosons W and Y :

$$\begin{aligned}
\mathcal{L}_{\text{mix}}^{\text{CGB}} &= \frac{g^2}{4} [v^2 + v'^2 + u^2 + u'^2 \\
&\quad + 2(v_1^2 + v_2^2 + \lambda_1^2 + \lambda_2^2)] (W_{\mu 1}^2 + W_{\mu 2}^2) \\
&+ \frac{g^2}{4} [v^2 + v'^2 + \omega^2
\end{aligned}$$

$$\begin{aligned}
& +2(v_1^2 + v_2^2 + \Lambda_1^2 + \Lambda_2^2)](W_{\mu 6}^2 + W_{\mu 7}^2) \\
& + g^2(\Lambda_1 v_1 + \lambda_1 v_1 + \Lambda_2 v_2 + \lambda_2 v_2) \\
& \times (W_{\mu 1} W_{\mu 6} - W_{\mu 2} W_{\mu 7}).
\end{aligned} \tag{60}$$

$\mathcal{L}_{\text{mix}}^{\text{CGB}}$ in (60) can be rewritten in matrix form as follows:

$$\mathcal{L}_{\text{mix}}^{\text{CGB}} = \frac{g^2}{4} (W_{\mu}^{\prime-} \ Y_{\mu}^{\prime-}) M_{WY}^2 (W_{\mu}^{\prime+} \ Y_{\mu}^{\prime+})^T, \tag{61}$$

where

$$M_{WY}^2 = 2 \begin{pmatrix} v^2 + v'^2 + u^2 + u'^2 + 2(v_1^2 + v_2^2 + \lambda_1^2 + \lambda_2^2) & 2(\Lambda_1 v_1 + \lambda_1 v_1 + \Lambda_2 v_2 + \lambda_2 v_2) \\ 2(\Lambda_1 v_1 + \lambda_1 v_1 + \Lambda_2 v_2 + \lambda_2 v_2) & v^2 + v'^2 + \omega^2 + 2(v_1^2 + v_2^2 + \Lambda_1^2 + \Lambda_2^2) \end{pmatrix}. \tag{62}$$

The matrix M_{WY}^2 in (62) can be diagonalized as follows:

$$U_2^T M_{WY}^2 U_2 = \text{diag}(M_W^2, M_Y^2), \tag{63}$$

where

$$\begin{aligned}
M_W^2 &= \frac{g^2}{4} \{2(\lambda_1^2 + \lambda_2^2 + 2v_1^2 + 2v_2^2 + \Lambda_1^2 + \Lambda_2^2) \\
& + \omega^2 + u^2 + u'^2 + 2(v^2 + v'^2) - \sqrt{\Gamma}\},
\end{aligned} \tag{64}$$

$$\begin{aligned}
M_Y^2 &= \frac{g^2}{4} \{2(\lambda_1^2 + \lambda_2^2 + 2v_1^2 + 2v_2^2 + \Lambda_1^2 + \Lambda_2^2) \\
& + \omega^2 + u^2 + u'^2 + 2(v^2 + v'^2) + \sqrt{\Gamma}\},
\end{aligned}$$

with

$$\begin{aligned}
\Gamma &= 4\lambda_1^4 + 4\Lambda_1^4 + (2\lambda_2^2 - 2\Lambda_2^2 - \omega^2 + u^2 + u'^2)^2 \\
& - 4\lambda_1^2(2\Lambda_1^2 - 2\lambda_2^2 + 2\Lambda_2^2 + \omega^2 - u^2 - u'^2 - 4v_1^2) \\
& - 4\Lambda_1^2(2\lambda_2^2 - 2\Lambda_2^2 - \omega^2 + u^2 + u'^2 - 4v_1^2) \\
& + 32\Lambda_1(\lambda_2 + \Lambda_2)v_1v_2 + 16(\lambda_2 + \Lambda_2)^2v_2^2 \\
& + 32\lambda_1v_1(\Lambda_1v_1 + \lambda_2v_2 + \Lambda_2v_2).
\end{aligned} \tag{65}$$

With corresponding eigenstates, the charged gauge boson mixing matrix takes the form:

$$U_2 = \begin{pmatrix} \cos \theta & -\sin \theta \\ \sin \theta & \cos \theta \end{pmatrix}. \tag{66}$$

The mixing angle θ is given by

$$\tan \theta = \frac{4(\lambda_1 + \Lambda_1)v_1 + 4(\lambda_2 + \Lambda_2)v_2}{2\lambda_1^2 - 2\Lambda_1^2 + 2\lambda_2^2 - 2\Lambda_2^2 - \omega^2 + u^2 + u'^2 - \sqrt{\Gamma}}. \tag{67}$$

The physical charged gauge bosons are defined

$$\begin{aligned}
W_{\mu}^{-} &= \cos \theta W_{\mu}^{\prime-} + \sin \theta Y_{\mu}^{\prime-}, \\
Y_{\mu}^{-} &= -\sin \theta W_{\mu}^{\prime-} + \cos \theta Y_{\mu}^{\prime-}.
\end{aligned} \tag{68}$$

In our model, the following limit is often taken into account:

$$\lambda_{1,2}^2, v_{1,2}^2 \ll u^2, u'^2, v^2, v'^2 \ll \omega^2 \sim \Lambda_{1,2}^2. \tag{69}$$

With the help of (69), the Γ in (65) becomes

$$\begin{aligned}
\sqrt{\Gamma} &\simeq (2\Lambda_1^2 + 2\Lambda_2^2 + \omega^2 - u^2 - u'^2) \\
& + \frac{16\Lambda_1\Lambda_2v_1v_2 + 8\Lambda_2^2v_2^2}{2\Lambda_1^2 + 2\Lambda_2^2 + \omega^2 - u^2 - u'^2}.
\end{aligned} \tag{70}$$

It is then

$$M_W^2 \simeq \frac{g^2}{2} (u^2 + u'^2 + v^2 + v'^2) - \frac{g^2}{2} \Delta_{M_W^2}, \tag{71}$$

with

$$\Delta_{M_W^2} = \frac{4(2\Lambda_1\Lambda_2v_1v_2 + \Lambda_2^2v_2^2)}{2\Lambda_1^2 + 2\Lambda_2^2 + \omega^2 - u^2 - u'^2}. \tag{72}$$

In the limit $v_{1,2} \rightarrow 0$ the mixing angle θ tends to zero, $\Gamma = 2\Lambda_1^2 + 2\Lambda_2^2 + \omega^2 - u^2 - u'^2$, and one has

$$\begin{aligned}
M_W^2 &= \frac{g^2}{2} (u^2 + u'^2 + v^2 + v'^2), \\
M_Y^2 &= \frac{g^2}{2} (2\Lambda_1^2 + 2\Lambda_2^2 + \omega^2 + v^2 + v'^2).
\end{aligned} \tag{73}$$

With the help of (69), one can estimate

$$\tan \theta \simeq \frac{4\Lambda_1v_1 + 4\Lambda_2v_2}{-2\Lambda_1^2 - 2\Lambda_2^2 - \omega^2 - 2(\Lambda_1^2 + \Lambda_2^2)} \sim \frac{v_i}{\Lambda_i}, \tag{74}$$

$(i = 1, 2).$

In addition, from (73), it follows that M_W^2 is much smaller than M_Y^2 . Note that, due to the above mixing, the new gauge boson Y will give a contribution to neutrinoless double beta decay (for details, see [123–125]).

$\mathcal{L}_{\text{mix}}^{\text{NGB}}$ is the Lagrangian that describes the mixing among the neutral gauge bosons W_3, W_8, B, W_4 . The mass Lagrangian in this case has the form

$$\begin{aligned} \mathcal{L}_{\text{mix}}^{\text{NGB}} &= \frac{(v^2 + v'^2)}{324} (-9gW_{\mu 3} + 3\sqrt{3}gW_{\mu 8} + 2\sqrt{6}g_X B_\mu)^2 \\ &+ \frac{\omega^2}{108} (27g^2W_{\mu 4}^2 + 36g^2W_{\mu 8}^2 \\ &+ 12\sqrt{2}gg_XW_{\mu 8}B_\mu + 2g_X^2B_\mu^2) \\ &+ \frac{(u^2 + u'^2)}{324} \left[81g^2W_{\mu 4}^2 \right. \\ &\quad \left. + (-9gW_{\mu 3} - 3\sqrt{3}gW_{\mu 8} + \sqrt{6}g_X B_\mu)^2 \right] \\ &+ \frac{g^2}{6} \left[2(\Lambda_1 v_1 + \Lambda_2 v_2) (3W_{\mu 3}W_{\mu 4} - 5\sqrt{3}W_{\mu 4}W_{\mu 8}) \right. \\ &\quad + 3(v_1^2 + v_2^2 + 2\lambda_1^2 + 2\lambda_2^2)W_{\mu 3}^2 \\ &\quad + 3(4v_1^2 + 4v_2^2 + \lambda_1^2 + \lambda_2^2 + \Lambda_1^2 + \Lambda_2^2 \\ &\quad \quad \left. + 2\Lambda_1\lambda_1 + 2\Lambda_2\lambda_2)W_{\mu 4}^2 \right. \\ &\quad + 2\sqrt{3}(-v_1^2 - v_2^2 + 2\lambda_1^2 + 2\lambda_2^2)W_{\mu 3}W_{\mu 8} \\ &\quad + (v_1^2 + v_2^2 + 2\lambda_1^2 + 2\lambda_2^2 + 8\Lambda_1^2 + \Lambda_2^2)W_{\mu 8}^2 \\ &\quad + 18(\lambda_1 v_1 + \lambda_2 v_2)W_{\mu 3}W_{\mu 4} \\ &\quad \left. + 2\sqrt{3}(\lambda_1 v_1 + \lambda_2 v_2)W_{\mu 4}W_{\mu 8} \right] \\ &+ \frac{2}{27}t^2g^2(\lambda_1^2 + \lambda_2^2 + \Lambda_1^2 + \Lambda_2^2 + 2v_1^2 + 2v_2^2)B_\mu^2 \\ &- \frac{2}{3}\sqrt{\frac{2}{3}}tg^2(\lambda_1^2 + \lambda_2^2 + v_1^2 + v_2^2)W_{\mu 3}B_\mu \\ &- \frac{4}{3}\sqrt{\frac{2}{3}}tg^2[(\lambda_1 + \Lambda_1)v_1 + (\lambda_2 + \Lambda_2)v_2]W_{\mu 4}B_\mu \\ &- \frac{2\sqrt{2}}{9}tg^2(\lambda_1^2 + \lambda_2^2 - v_1^2 - v_2^2 - 2\Lambda_1^2 - 2\Lambda_2^2)W_{\mu 8}B_\mu. \end{aligned} \quad (75)$$

On the basis of $(W_{\mu 3}, W_{\mu 8}, B_\mu, W_{\mu 4})$, the $\mathcal{L}_{\text{mix}}^{\text{NGB}}$ in (75) can be rewritten in matrix form:

$$\begin{aligned} \mathcal{L}_{\text{mix}}^{\text{NGB}} &\equiv \frac{1}{2}V^T M^2 V, \\ V^T &= (W_{\mu 3}, W_{\mu 8}, B_\mu, W_{\mu 4}), \\ M^2 &= \frac{g^2}{4} \begin{pmatrix} M_{11}^2 & M_{12}^2 & M_{13}^2 & M_{14}^2 \\ M_{12}^2 & M_{22}^2 & M_{23}^2 & M_{24}^2 \\ M_{13}^2 & M_{23}^2 & M_{33}^2 & M_{34}^2 \\ M_{14}^2 & M_{24}^2 & M_{34}^2 & M_{44}^2 \end{pmatrix}, \end{aligned} \quad (76)$$

where

$$\begin{aligned} M_{11}^2 &= 2(v^2 + v'^2 + u^2 + u'^2 + 2v_1^2 + 2v_2^2 + 4\lambda_1^2 + 4\lambda_2^2), \\ M_{12}^2 &= -\frac{2\sqrt{3}}{3}(v^2 + v'^2 - u^2 - u'^2 + 2v_1^2 + 2v_2^2 - 4\lambda_1^2 - 4\lambda_2^2), \\ M_{13}^2 &= -\frac{2}{3}\sqrt{\frac{2}{3}}t(2v^2 + 2v'^2 + u^2 + u'^2 \\ &\quad + 4\lambda_1^2 + 4\lambda_2^2 + 4v_1^2 + 4v_2^2), \\ M_{14}^2 &= 4(\Lambda_1 v_1 + \Lambda_2 v_2) + 12(\lambda_1 v_1 + \lambda_2 v_2), \\ M_{22}^2 &= \frac{2}{3}(v^2 + v'^2 + 4\omega^2 + u^2 + u'^2 + 2v_1^2 + 2v_2^2 \\ &\quad + 4\lambda_1^2 + 4\lambda_2^2 + 16\Lambda_1^2 + 16\Lambda_2^2), \\ M_{23}^2 &= \frac{2\sqrt{2}t}{9}(2v^2 + 2v'^2 + 2\omega^2 - u^2 - u'^2 - 4\lambda_1^2 - 4\lambda_2^2 \\ &\quad + 4v_1^2 + 4v_2^2 + 8\Lambda_1^2 + 8\Lambda_2^2), \\ M_{24}^2 &= \frac{4}{\sqrt{3}}[\lambda_1 v_1 + \lambda_2 v_2 - 5(\Lambda_1 v_1 + \Lambda_2 v_2)], \\ M_{33}^2 &= \frac{4t^2}{27}(4v^2 + 4v'^2 + \omega^2 + u^2 + u'^2 + 4\lambda_1^2 + 4\lambda_2^2 \\ &\quad + 4\Lambda_1^2 + 4\Lambda_2^2 + 8v_1^2 + 8v_2^2), \\ M_{34}^2 &= -\frac{16}{3}\sqrt{\frac{2}{3}}t(\lambda_1 v_1 + \Lambda_1 v_1 + \lambda_2 v_2 + \Lambda_2 v_2), \\ M_{44}^2 &= 2(\omega^2 + u^2 + u'^2 + 8v_1^2 + 8v_2^2 + 2\lambda_1^2 + 2\lambda_2^2 \\ &\quad + 2\Lambda_1^2 + 2\Lambda_2^2 + 4\Lambda_1\lambda_1 + 4\Lambda_2\lambda_2). \end{aligned} \quad (77)$$

The matrix M^2 in (76) with elements in (77) has one exact eigenvalue, which is identified with the photon mass:

$$M_\gamma^2 = 0. \quad (78)$$

The corresponding eigenvector of M_γ^2 is

$$A_\mu = \begin{pmatrix} \frac{\sqrt{3}t}{\sqrt{4t^2 + 18}} \\ -\frac{t}{\sqrt{4t^2 + 18}} \\ \frac{3\sqrt{2}}{\sqrt{4t^2 + 18}} \\ 0 \end{pmatrix}. \quad (79)$$

Note that in the limit $\lambda_{1,2}, v_{1,2} \rightarrow 0$, $M_{14}^2 = M_{24}^2 = M_{34}^2 = 0$, and W_4 does not mix with $W_{3\mu}, W_{8\mu}, B_\mu$. In the general case $\lambda_{1,2}, v_{1,2} \neq 0$, the mass matrix in (76) contains one exact eigenvalues as in (78) with the corresponding eigenstate given in (79).

The mass matrix M^2 in (76) is diagonalized via two steps. In the first step, the basic $(W_{\mu 3}, W_{\mu 8}, B'_\mu, W_{4\mu})$ is transformed into the basic $(A_\mu, Z_\mu, Z'_\mu, W_{4\mu})$ by the matrix:

$$U_{\text{NGB}} = \begin{pmatrix} s_W & -c_W & 0 & 0 \\ -\frac{c_W t_W}{\sqrt{3}} & -\frac{s_W t_W}{\sqrt{3}} & \sqrt{1 - \frac{t_W^2}{3}} & 0 \\ c_W \sqrt{1 - \frac{t_W^2}{3}} & s_W \sqrt{1 - \frac{t_W^2}{3}} & \frac{t_W}{\sqrt{3}} & 0 \\ 0 & 0 & 0 & 1 \end{pmatrix}. \quad (80)$$

The corresponding eigenstates are given by

$$\begin{aligned} A_\mu &= s_W W_{3\mu} + c_W \left(-\frac{t_W}{\sqrt{3}} W_{8\mu} + \sqrt{1 - \frac{t_W^2}{3}} B_\mu \right), \\ Z_\mu &= -c_W W_{3\mu} + s_W \left(-\frac{t_W}{\sqrt{3}} W_{8\mu} + \sqrt{1 - \frac{t_W^2}{3}} B_\mu \right), \\ Z'_\mu &= \sqrt{1 - \frac{t_W^2}{3}} W_{8\mu} + \frac{t_W}{\sqrt{3}} B_\mu. \end{aligned} \quad (81)$$

To obtain (80) and (81) we have used the continuation of the gauge coupling constant g of the $SU(3)_L$ at the spontaneous symmetry breaking point, in which

$$t = \frac{3\sqrt{2}s_W}{\sqrt{3 - 4s_W^2}}. \quad (82)$$

On this basis, the mass matrix M^2 becomes

$$M'^2 = U_{\text{NGB}}^+ M^2 U_{\text{NGB}} = \frac{g^2}{4} \begin{pmatrix} 0 & 0 & 0 & 0 \\ 0 & M'_{22} & M'_{23} & M'_{24} \\ 0 & M'_{23} & M'_{33} & M'_{34} \\ 0 & M'_{24} & M'_{34} & M'_{44} \end{pmatrix}, \quad (83)$$

where

$$\begin{aligned} M'_{22} &= \frac{2}{c_W^2} (u^2 + u'^2 + v^2 + v'^2 + 4\lambda_1^2 + 4\lambda_2^2 + 2v_1^2 + 2v_2^2), \\ M'_{23} &= (2 [(1 - 2c_W^2)(u^2 + u'^2 + 4\lambda_1^2 + 4\lambda_2^2) \\ &\quad + v^2 + v'^2 + v_1^2 + v_2^2] \sqrt{\alpha_0}) (c_W^2)^{-1}, \\ M'_{24} &= -\frac{4}{c_W} (\Lambda_1 v_1 + \Lambda_2 v_2 + 3\lambda_1 v_1 + 3\lambda_2 v_2), \\ M'_{33} &= 32 (\Lambda_1^2 + \Lambda_2^2) c_W^2 \alpha_0 + 8\omega^2 c_W^2 \alpha_0 \\ &\quad + \frac{2}{c_W^2} (v^2 + v'^2 + 2v_1^2 + 2v_2^2) \alpha_0 \\ &\quad + \frac{2}{c_W^2} (2c_W^2 - 1)^2 (u^2 + u'^2) \alpha_0 \\ &\quad + \frac{8(2c_W^2 - 1)^2}{c_W^2} (\lambda_1^2 + \lambda_2^2) \alpha_0, \\ M'_{34} &= -\frac{4\sqrt{\alpha}}{c_W} \left[x_0 (\Lambda_1 v_1 + \Lambda_2 v_2) \right. \\ &\quad \left. + \left(2 - \frac{1}{\alpha_0} \right) (\lambda_1 v_1 + \lambda_2 v_2) \right], \\ M'_{44} &= 2 (u^2 + u'^2 + \omega^2 + 2\lambda_1^2 + 2\lambda_2^2 + 2\Lambda_1^2 + 2\Lambda_2^2 \\ &\quad + 4\lambda_1 \Lambda_1 + 4\lambda_2 \Lambda_2 + 8v_1^2 + 8v_2^2). \end{aligned} \quad (84)$$

In the approximation $\lambda_{1,2}^2, v_{1,2}^2 \ll \Lambda_{1,2}^2 \sim \omega^2$, we have

$$\begin{aligned} M'_{22} &= \frac{2}{c_W^2} (u^2 + u'^2 + v^2 + v'^2), \\ M'_{23} &= \frac{2 [(1 - 2c_W^2)(u^2 + u'^2) + v^2 + v'^2] \sqrt{\alpha_0}}{c_W^2}, \\ M'_{24} &= -\frac{4}{c_W} (\Lambda_1 v_1 + \Lambda_2 v_2), \\ M'_{33} &= 32 (\Lambda_1^2 + \Lambda_2^2) c_W^2 \alpha_0 + 8\omega^2 c_W^2 \alpha_0 \\ &\quad + \frac{2}{c_W^2} (v^2 + v'^2) \alpha_0 + \frac{2}{c_W^2} (2c_W^2 - 1)^2 (u^2 + u'^2) \alpha_0, \\ M'_{34} &= -\frac{4x_0 \sqrt{\alpha}}{c_W} (\Lambda_1 v_1 + \Lambda_2 v_2), \\ M'_{44} &= 2 (u^2 + u'^2 + \omega^2 + 2\Lambda_1^2 + 2\Lambda_2^2 + 4\lambda_1 \Lambda_1 + 4\lambda_2 \Lambda_2), \end{aligned} \quad (85)$$

with

$$\begin{aligned} s_W &= \sin \theta_W, & c_W &= \cos \theta_W, & t_W &= \tan \theta_W, \\ x_0 &= 4c_W^2 + 1, & \alpha_0 &= (4c_W^2 - 1)^{-1}. \end{aligned} \quad (86)$$

From (83), there exist mixings between Z_μ , Z'_μ and $W_{\mu 4}$. It is noteworthy that, in the limit $v_{1,2} = 0$, the elements M_{24}^{I2} and M_{34}^{I2} vanish. In this case there is no mixing between W_4 and Z_μ , Z'_μ .

In the second step, three bosons gain masses via seesaw mechanism

$$M_Z^2 = \frac{g^2}{4} \left[M_{22}^{I2} - (M^{\text{off}})^T (M_{2 \times 2}^{I2})^{-1} M^{\text{off}} \right], \quad (87)$$

where

$$M^{\text{off}} = \begin{pmatrix} M_{23}^{I2} \\ M_{24}^{I2} \end{pmatrix}, \quad M_{2 \times 2}^{I2} = \begin{pmatrix} M_{33}^{I2} & M_{34}^{I2} \\ M_{34}^{I2} & M_{44}^{I2} \end{pmatrix}. \quad (88)$$

Combination of (87), (88), and (85) yields

$$M_Z^2 = \frac{g^2 (u^2 + u'^2 + v^2 + v'^2)}{2c_W^2} - \frac{g^2}{2c_W^2} \Delta_{M_z^2}, \quad (89)$$

where

$$\Delta_{M_z^2} = \frac{4\Delta_z^2 (4c_W^4 x_3 - 2x_0 x_1 + x_4) + x_1^2 x_2}{x_2 (x_4 + 4c_W^4 x_3) - 4\Delta_z^2 x_0^2}, \quad (90)$$

with

$$\begin{aligned} x_1 &= (1 - 2c_W^2)(u^2 + u'^2) + v^2 + v'^2, \\ x_2 &= 2\Lambda_1 (2\lambda_1 + \Lambda_1) + 2\Lambda_2 (2\lambda_2 + \Lambda_2) + \omega^2 + u^2 + u'^2, \\ x_3 &= 4\Lambda_1^2 + 4\Lambda_2^2 + \omega^2 + u^2 + u'^2, \\ x_4 &= (1 - 4c^2)(u^2 + u'^2) + v^2 + v'^2, \\ \Delta_z &= \Lambda_1 v_1 + \Lambda_2 v_2. \end{aligned} \quad (91)$$

The ρ parameter in our model is given by

$$\rho = \frac{M_W^2}{M_Z^2 \cos^2 \theta_W} = 1 + \frac{\delta_{wz}}{M_Z^2} \equiv 1 + \delta_{\text{tree}}, \quad (92)$$

where

$$\delta_{wz} = \frac{g^2}{2c_W^2} (\Delta_{M_z^2} - \Delta_{M_w^2}). \quad (93)$$

Let us assume the relations (A.17) and put $v_2 \equiv v_s$, $\omega = \Lambda_2 \equiv \Lambda_s$, and then

$$\Delta_{M_z^2} - \Delta_{M_w^2} \approx \frac{8(k^2 + 1)v_s^2}{2k^2 + 3} \left(\frac{k^2 + 1}{2c_W^2} - 1 \right). \quad (94)$$

From (92)–(94) we have

$$\delta_{\text{tree}} = \frac{g^2}{2c_W^2} \frac{1}{M_Z^2} \frac{8(k^2 + 1)v_s^2}{2k^2 + 3} \left(\frac{k^2 + 1}{2c_W^2} - 1 \right). \quad (95)$$

The experimental value of the ρ parameter and M_W are, respectively, given in [7]

$$\begin{aligned} \rho &= 1.0004_{-0.0004}^{+0.0003} \quad (\delta_{\text{tree}} = 0.0004_{-0.0004}^{+0.0003}), \\ s_W^2 &= 0.23116 \pm 0.00012, \\ M_W &= 80.358 \pm 0.015 \text{ GeV}. \end{aligned} \quad (96)$$

It means

$$0 \leq \delta_{\text{tree}} \leq 0.0007. \quad (97)$$

From (95) one can make the relations between v , g , and k . Indeed, we have

$$v = \pm \frac{c_W^2 \sqrt{\delta_{\text{tree}}} \sqrt{2k^2 + 3} M_Z}{g \sqrt{2k^2 + 2} \sqrt{k^2 + 1 - 2c_W^2}}. \quad (98)$$

Figure 1 gives the relation between v_s and g , k provided that $g = 0.5$, and $k \in (0.9, 1.1)$ in which $|v_s| \in (0, 8.0)$ GeV.

Figure 2 gives the relation between g and δ_{tree} , v_s provided that $k = 1$ and $\delta_{\text{tree}} \in (0, 0.0007)$, $v_s \in (0, 8.0)$ GeV in which $|g| \in (0, 2.0)$ GeV. The conditions (69) are satisfied. The Figure 3 gives the relation between k and g , v_s provided $\delta_{\text{tree}} = 0.0005$ and $g \in (0.4, 0.6)$, $v_s \in (0, 8.0)$ GeV in which $k \in (1, 3)$ GeV (k is a real number, Figure 3(a)) or $k = ik_1$, $k_1 \in (-1.2, -1.05)$ GeV (k is a pure complex number, Figure 3(b)). The conditions (69) are satisfied. From Figure 3 we see that a lot of values of k that is different from the unit but nearly it still can fit the recent experimental data [7]. It means that the difference of $\langle s_1 \rangle$ and $\langle s_2 \rangle$ as mentioned in this work is necessary.

Diagonalizing the mass matrix $M_{2 \times 2}^{I2}$, we get two new physical gauge bosons

$$\begin{aligned} Z''_\mu &= \cos \phi Z'_\mu + \sin \phi W_{\mu 4}, \\ W'_{\mu 4} &= -\sin \phi Z'_\mu + \cos \phi W_{\mu 4}. \end{aligned} \quad (99)$$

With the approximation as in (69), the mixing angle ϕ is given by

$$\tan \phi \approx \frac{2\sqrt{\alpha_0} c_W (\Lambda_1 v_1 + \Lambda_2 v_2) x_0}{-4\alpha_0 c_W^4 x_3 + c_W^2 x_2 - \alpha_0 x_4} \sim \frac{v_1}{\Lambda_1} \sim \frac{v_2}{\Lambda_2} \quad (100)$$

provided that $v_1 \sim v_2$, $\Lambda_1 \sim \Lambda_2$.

In the limit $\lambda_{1,2}, v_{1,2} \rightarrow 0$ the mixing angle ϕ tends to zero, and the physical mass eigenvalues are defined by

$$M_{Z''_\mu}^2 = \frac{g^2}{2c_W^2} (x_4 + 4c_W^4 x_3), \quad (101)$$

$$M_{W'_{\mu 4}}^2 = \frac{g^2}{2} (u^2 + u'^2 + \omega^2 + 2\Lambda_1^2 + 2\Lambda_2^2).$$

From (59) and (101) we see that the $W'_{\mu 4}$ and W_5 components have the same mass in the limit $\lambda_{1,2}, v_{1,2} \rightarrow 0$. So we should identify the combination of $W'_{\mu 4}$ and $W_{\mu 5}$

$$\sqrt{2} X'_\mu = W'_{\mu 4} - i W_{\mu 5}, \quad (102)$$

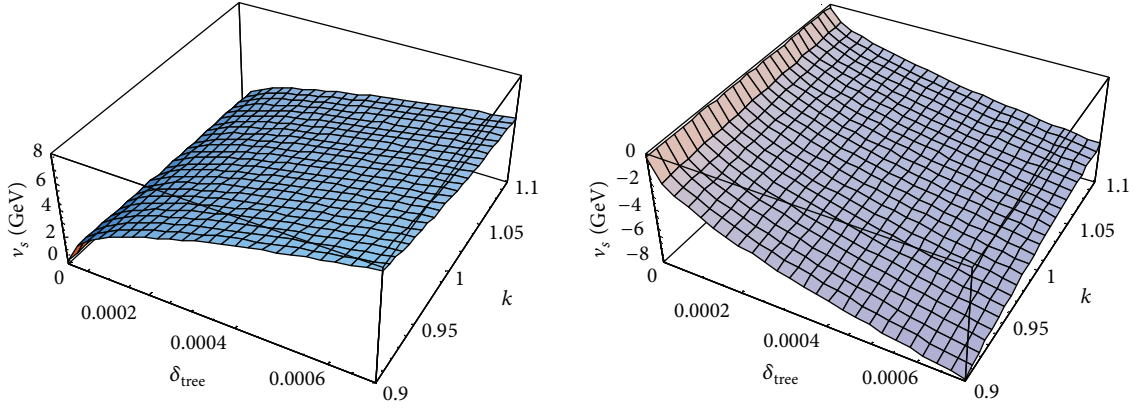
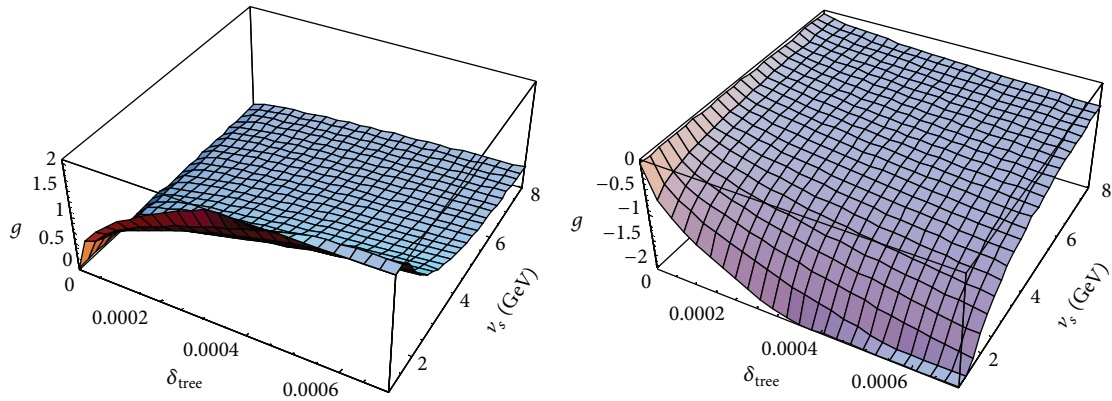
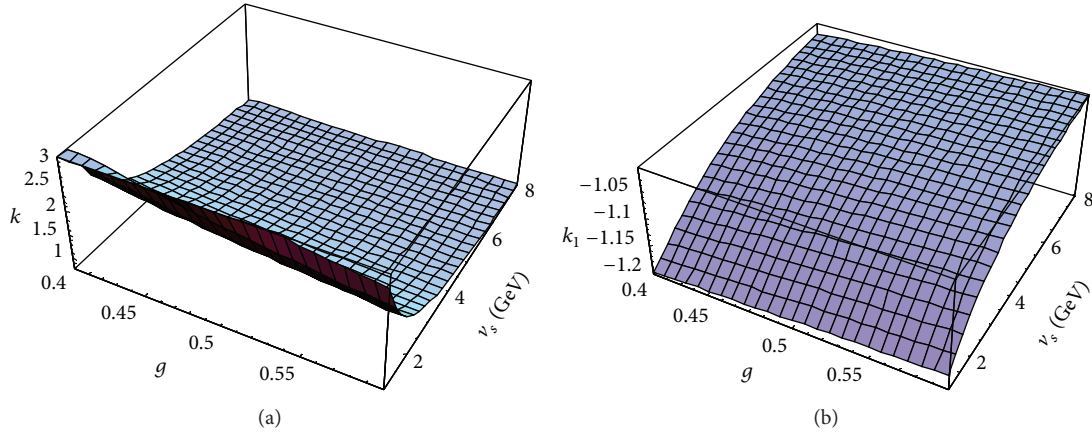
 FIGURE 1: The relation between v_s and g, k with $g = 0.5$ and $k \in (0.9, 1.1)$.

 FIGURE 2: The relation between g and $\delta_{\text{tree}}, v_s$ with $k = 1$ and $\delta_{\text{tree}} \in (0, 0.0007)$, $v_s \in (0, 8.0)$ GeV.

 FIGURE 3: The relation between k and g, v_s provided that $\delta_{\text{tree}} = 0.0005$ and $g \in (0.4, 0.6)$, $v_s \in (0, 8.0)$ GeV.

as physical neutral non-Hermitian gauge boson. The subscript “0” denotes neutrality of gauge boson X . Notice that the identification in (102) only can be acceptable with the limit $\lambda_{1,2}, v_{1,2} \rightarrow 0$. In general, it is not true because of the difference in masses of $W'_{\mu 4}$ and $W_{\mu 5}$ as in (58) and (99).

The expressions (74) and (100) show that, with the limit (69), the mixings between the charged gauge bosons $W - Y$ and the neutral ones $Z' - W_4$ are in the same order since

they are proportional to v_i/Λ_i ($i = 1, 2$). In addition, from (101), $M_{Z'_\mu}^2 \simeq g^2(4\Lambda_1^2 + 4\Lambda_2^2 + \omega^2)$ is little bigger than $M_{W'_{\mu 4}}^2 \simeq (g^2/2)(\omega^2 + 2\Lambda_1^2 + 2\Lambda_2^2)$ (or $M_{X_\mu^0}^2$), and $|M_Y^2 - M_{X_\mu^0}^2| = (g^2/2)(u^2 + u'^2 - v^2 - v'^2)$ is little smaller than $M_W^2 = (g^2/2)(u^2 + u'^2 + v^2 + v'^2)$. In that limit, the masses of X_μ^0 and Y degenerate.

7. Conclusions

In this paper, we have constructed a new S_4 model based on $SU(3)_C \otimes SU(3)_L \otimes U(1)_X$ gauge symmetry responsible for fermion masses and mixing which is different from our previous work in [112]. Neutrinos get masses from only an antisextet which is in a doublet under S_4 . We argue how flavor mixing patterns and mass splitting are obtained with a perturbed S_4 symmetry by the difference of VEV components of the antisextet under S_4 . We have pointed out that this model is simpler than those of S_3 and S_4 [111, 112] with the fewer number of Higgs multiplets needed in order to allow the fermions to gain masses but with the simple scalar Higgs potential. Quark mixing matrix is unity at the tree level. The realistic neutrino mixing in which $\theta_{13} \neq 0$ can be obtained if the direction for breaking $S_4 \rightarrow K_4$ takes place. This corresponds to the requirement on the difference of VEV components of the antisextet under S_4 group. As a result, the value of θ_{13} is a small perturbation by $|\lambda_1 - \lambda_2|$. The assignation of VEVs to antisextet leads to the mixing of the new gauge bosons and those in the SM. The mixing in the charged gauge bosons as well as the neutral gauge boson was considered.

Appendices

A. Vacuum Alignment

We can separate the general scalar potential into

$$V_{\text{total}} = V_{\text{tri}} + V_{\text{sext}} + V_{\text{tri-sext}} + \bar{V}, \quad (\text{A.1})$$

where V_{tri} and V_{sext} , respectively, consist of the $SU(3)_L$ scalar triplets and sextets, whereas $V_{\text{tri-sext}}$ contains the terms connecting the two sectors. Moreover $V_{\text{tri-sext}}$ conserve \mathcal{L} -charge and S_4 symmetry, while \bar{V} includes possible soft terms explicitly violating these charges. Here the soft terms as we meant include the trilinear and quartic ones as well. The reason for imposing \bar{V} will be shown below.

The details on the potentials are given as follows. We first denote $V(X \rightarrow X_1, Y \rightarrow Y_1, \dots) \equiv V(X, Y, \dots)|_{X=X_1, Y=Y_1, \dots}$. Notice also that $(\text{Tr } A)(\text{Tr } B) = \text{Tr}(A \text{Tr } B)$. V_{tri} is a sum of

$$V(\chi) = \mu_\chi^2 \chi^\dagger \chi + \lambda^\chi (\chi^\dagger \chi)^2,$$

$$V(\phi) = V(\chi \rightarrow \phi), \quad V(\phi') = V(\phi \rightarrow \phi'),$$

$$V(\eta) = V(\phi \rightarrow \eta), \quad V(\eta') = V(\phi \rightarrow \eta'),$$

$$V(\chi, \phi) = \lambda_1^{\phi\chi} (\phi^\dagger \phi) (\chi^\dagger \chi) + \lambda_2^{\phi\chi} (\phi^\dagger \chi) (\chi^\dagger \phi),$$

$$V(\chi, \phi') = V(\phi \rightarrow \phi', \chi), \quad V(\chi, \eta) = V(\phi \rightarrow \eta, \chi),$$

$$V(\chi, \eta') = V(\phi \rightarrow \eta', \chi),$$

$$V(\phi, \phi') = V(\phi, \chi \rightarrow \phi') + \lambda_3^{\phi\phi'} (\phi^\dagger \phi') (\phi^\dagger \phi')$$

$$+ \lambda_4^{\phi\phi'} (\phi'^{\dagger} \phi) (\phi'^{\dagger} \phi),$$

$$V(\phi, \eta) = V(\phi, \chi \rightarrow \eta), \quad V(\phi, \eta') = V(\phi, \chi \rightarrow \eta'),$$

$$V(\phi', \eta) = V(\phi \rightarrow \phi', \chi \rightarrow \eta),$$

$$V(\phi', \eta') = V(\phi \rightarrow \phi', \chi \rightarrow \eta'),$$

$$V(\eta, \eta') = V(\phi \rightarrow \eta, \chi \rightarrow \eta') + \lambda_3^{\eta\eta'} (\eta^\dagger \eta') (\eta^\dagger \eta') \\ + \lambda_4^{\eta\eta'} (\eta'^{\dagger} \eta) (\eta'^{\dagger} \eta),$$

$$V_{\chi\phi\phi'\eta\eta'} = \mu_1 \chi \phi \eta + \mu_1' \chi \phi' \eta' + \lambda_1^1 (\phi^\dagger \phi')_{\underline{1}'} (\eta^\dagger \eta')_{\underline{1}'} \\ + \lambda_1^2 (\phi^\dagger \eta')_{\underline{1}'} (\eta^\dagger \phi')_{\underline{1}'} + \lambda_1^3 (\phi^\dagger \phi')_{\underline{1}'} (\eta^\dagger \eta)_{\underline{1}'} \\ + \lambda_1^4 (\phi^\dagger \eta)_{\underline{1}'} (\eta^\dagger \phi')_{\underline{1}'} + \lambda_1^5 (\phi^\dagger \eta)_{\underline{1}'} (\phi'^{\dagger} \eta')_{\underline{1}'} \\ + \lambda_1^6 (\phi^\dagger \eta')_{\underline{1}'} (\phi'^{\dagger} \eta)_{\underline{1}'} + h.c. \quad (\text{A.2})$$

V_{sext} is only of $V(s)$,

$$V(s) = \mu_s^2 \text{Tr}(s^\dagger s) + \lambda_1^s \text{Tr}[(s^\dagger s)_{\underline{1}} (s^\dagger s)_{\underline{1}}] \\ + \lambda_2^s \text{Tr}[(s^\dagger s)_{\underline{1}'} (s^\dagger s)_{\underline{1}'}] + \lambda_3^s \text{Tr}[(s^\dagger s)_{\underline{2}} (s^\dagger s)_{\underline{2}}] \\ + \lambda_4^s \text{Tr}(s^\dagger s)_{\underline{1}} \text{Tr}(s^\dagger s)_{\underline{1}} + \lambda_5^s \text{Tr}(s^\dagger s)_{\underline{1}'} \text{Tr}(s^\dagger s)_{\underline{1}'} \\ + \lambda_6^s \text{Tr}(s^\dagger s)_{\underline{2}} \text{Tr}(s^\dagger s)_{\underline{2}}, \quad (\text{A.3})$$

And $V_{\text{tri-sext}}$ is a sum of

$$V(\chi, s) = \lambda_1^{s\chi} (\chi^\dagger \chi) \text{Tr}(s^\dagger s) + \lambda_2^{s\chi} (\chi^\dagger s^\dagger)_{\underline{2}} (s\chi)_{\underline{2}} \\ + \lambda_3^{s\chi} (\chi^\dagger s)_{\underline{2}} (s^\dagger \chi)_{\underline{2}},$$

$$V(\phi, s) = V(\chi \rightarrow \phi, s), \quad V(\phi', s) = V(\chi \rightarrow \phi', s),$$

$$V(\eta, s) = V(\chi \rightarrow \eta, s), \quad V(\eta', s) = V(\chi \rightarrow \eta', s),$$

$$V_{s\chi\phi\phi'\eta\eta'} = (\lambda_1' \phi^\dagger \phi' + \lambda_2' \eta^\dagger \eta') \text{Tr}(s^\dagger s)_{\underline{1}'} \\ + \lambda_3' [(\phi^\dagger s^\dagger) (s\phi')]_{\underline{1}} + \lambda_4' [(\eta^\dagger s^\dagger) (s\eta')]_{\underline{1}} + h.c. \quad (\text{A.4})$$

To provide the Majorana masses for the neutrinos, the lepton number must be broken. This can be achieved via the scalar potential violating $U(1)_{\mathcal{L}}$. However, the other symmetries should be conserved. The violating \mathcal{L} potential up to quartic interactions is given as

$$\bar{V} = [\bar{\lambda}_1 \text{Tr}(s^\dagger s)_{\underline{1}} + \bar{\lambda}_2 \eta^\dagger \chi + \bar{\lambda}_3 \eta^\dagger \eta + \bar{\lambda}_4 \eta'^{\dagger} \eta' \\ + \bar{\lambda}_5 \eta^\dagger \eta' + \bar{\lambda}_6 \eta'^{\dagger} \eta + \bar{\lambda}_7 \phi^\dagger \phi + \bar{\lambda}_8 \phi'^{\dagger} \phi' \\ + \bar{\lambda}_9 \phi^\dagger \phi' + \bar{\lambda}_{10} \phi'^{\dagger} \phi] \eta^\dagger \chi$$

$$\begin{aligned}
& + [\bar{\lambda}_{11} \text{Tr}(s^\dagger s)_{\underline{1}'} + \bar{\lambda}_{12} \eta'^{\dagger} \chi + \bar{\lambda}_{13} \eta'^{\dagger} \eta + \bar{\lambda}_{14} \eta'^{\dagger} \eta' \\
& \quad + \bar{\lambda}_{15} \eta'^{\dagger} \eta' + \bar{\lambda}_{16} \eta'^{\dagger} \eta + \bar{\lambda}_{17} \phi^\dagger \phi + \bar{\lambda}_{18} \phi'^{\dagger} \phi' \\
& \quad + \bar{\lambda}_{19} \phi^\dagger \phi' + \bar{\lambda}_{20} \phi'^{\dagger} \phi]_{\underline{1}'} \eta'^{\dagger} \chi \\
& + \bar{\lambda}_{21} (\eta'^{\dagger} \phi) (\phi^\dagger \chi) + \bar{\lambda}_{22} (\eta'^{\dagger} \phi')_{\underline{1}'} (\phi'^{\dagger} \chi)_{\underline{1}'} \\
& + \bar{\lambda}_{23} (\eta'^{\dagger} \phi)_{\underline{1}'} (\phi'^{\dagger} \chi)_{\underline{1}'} + \bar{\lambda}_{24} (\eta'^{\dagger} \phi')_{\underline{1}'} (\phi'^{\dagger} \chi)_{\underline{1}'} \\
& + \bar{\lambda}_{25} (\eta'^{\dagger} s^\dagger)_{\underline{2}} (s \chi)_{\underline{2}} + \bar{\lambda}_{26} (\eta'^{\dagger} s^\dagger)_{\underline{2}} (s \chi)_{\underline{2}} + h.c.
\end{aligned} \tag{A.5}$$

We have not explicitly written, but there must additionally exist the terms in \bar{V} explicitly violating the only S_4 symmetry or both the S_4 and \mathcal{L} -charge too. In the following, most of them will be omitted, and only the terms of the kind of interest will be provided.

There are the several scalar sectors corresponding to the expected VEV directions. The first direction, $0 \neq \langle s_1 \rangle \neq \langle s_2 \rangle \neq 0$, S_4 , is broken into a subgroup including the elements $\{1, TS^2 T^2, S^2, T^2 S^2 T\}$ which is isomorphic to the Klein four-group [75] [$S = (1234)$, $T = (123)$], obeying the relations $S^4 = T^3 = 1$, $ST^2 S = T$, are generators of S_4 group given in [112]. The second direction, $\langle s_1 \rangle = \langle s_2 \rangle = \langle s \rangle \neq 0$, S_4 , is broken into D_4 . The third direction, $0 = \langle s_1 \rangle \neq \langle s_2 \rangle$, or $0 = \langle s_2 \rangle \neq \langle s_1 \rangle$, S_4 , is broken into A_4 . As mentioned before, to obtain a realistic neutrino spectrum, we have thus imposed both of the first and the second directions to be performed.

Let us now consider the potential V_{tri} . The flavons χ , ϕ , ϕ' , η , η' with their VEVs aligned in the same direction (all of them are singlets) are an automatic solution from the minimization conditions of V_{tri} . To explicitly see this, in the system of equations for minimization, let us put $v^* = v$, $v'^* = v'$, $u^* = u$, $u'^* = u'$, and $v_\chi^* = v_\chi$. Then the potential minimization conditions for triplets reduce to

$$\begin{aligned}
\frac{\partial V_{\text{tri}}}{\partial \omega} = 4\lambda^\chi \omega^3 + 2 \left(\mu_\chi^2 + \lambda_1^{\chi\eta} u^2 + \lambda_1^{\chi\eta'} u'^2 + \lambda_1^{\chi\phi} v^2 \right. \\
\left. + \lambda_1^{\chi\phi'} v'^2 \right) \omega - \mu_1 u v - \mu'_1 u' v' = 0,
\end{aligned} \tag{A.6}$$

$$\begin{aligned}
\frac{\partial V_{\text{tri}}}{\partial v} = 4\lambda^\phi v^3 \\
+ 2 \left[\mu_\phi^2 + \lambda_1^{\phi\eta} u^2 + \lambda_1^{\phi\eta'} u'^2 \right. \\
\left. + \left(\lambda_1^{\phi\phi'} + \lambda_2^{\phi\phi'} + \lambda_3^{\phi\phi'} + \lambda_4^{\phi\phi'} \right) v'^2 + \omega^2 \lambda_1^{\phi\chi} \right] v \\
+ \left(\lambda_1^1 + \lambda_1^2 + \lambda_1^3 \right) u u' v' - \mu_1 \omega u = 0,
\end{aligned} \tag{A.7}$$

$$\begin{aligned}
\frac{\partial V_{\text{tri}}}{\partial v'} = 4\lambda^{\phi'} v'^3 \\
+ 2 \left[\mu_{\phi'}^2 + \lambda_1^{\phi'\eta} u^2 + \lambda_1^{\phi'\eta'} u'^2 \right. \\
\left. + \left(\lambda_1^{\phi\phi'} + \lambda_2^{\phi\phi'} + \lambda_3^{\phi\phi'} + \lambda_4^{\phi\phi'} \right) v^2 + \omega^2 \lambda_1^{\phi'\chi} \right] v' \\
+ \left(\lambda_1^1 + \lambda_1^2 + \lambda_1^3 \right) u u' v - \mu'_1 \omega u' = 0,
\end{aligned} \tag{A.8}$$

$$\begin{aligned}
\frac{\partial V_{\text{tri}}}{\partial u} = 4\lambda^\eta u^3 \\
+ 2 \left[\mu_\eta^2 + \left(\lambda_1^{\eta\eta'} + \lambda_2^{\eta\eta'} + \lambda_3^{\eta\eta'} + \lambda_4^{\eta\eta'} \right) u'^2 \right. \\
\left. + \lambda_1^{\phi\eta} v^2 + \lambda_1^{\phi'\eta} v'^2 + \omega^2 \lambda_1^{\eta\chi} \right] u \\
+ \left(\lambda_1^1 + \lambda_1^2 + \lambda_1^3 \right) u' v v' - \mu_1 \omega v = 0,
\end{aligned} \tag{A.9}$$

$$\begin{aligned}
\frac{\partial V_{\text{tri}}}{\partial u'} = 4\lambda^{\eta'} u'^3 \\
+ 2 \left[\mu_{\eta'}^2 + \left(\lambda_1^{\eta\eta'} + \lambda_2^{\eta\eta'} + \lambda_3^{\eta\eta'} + \lambda_4^{\eta\eta'} \right) u^2 \right. \\
\left. + \lambda_1^{\phi\eta'} v^2 + \lambda_1^{\phi'\eta'} v'^2 + \omega^2 \lambda_1^{\eta'\chi} \right] u' \\
+ \left(\lambda_1^1 + \lambda_1^2 + \lambda_1^3 \right) u v v' - \mu'_1 \omega v' = 0.
\end{aligned} \tag{A.10}$$

It is easily shown that the derivatives of V_{tri} with respect to the variables u , u' , v , v' shown in (A.7), (A.8), (A.9), and (A.10) are symmetric to each other. The system of (A.6)–(A.10) always has the solution (u, v, u', v') as expected, even though it is complicated. It is also noted that the above alignment is only one of the solutions to be imposed to have the desirable results. We have evaluated that (A.7)–(A.10) have the same structure solution. Consequently, to have a simple solution, we can assume that $u = u' = v = v'$. In this case, (A.7)–(A.10) reduce a unique equation, and system of (A.6)–(A.10) becomes

$$\begin{aligned}
\frac{\partial V_{\text{tri}}}{\partial \omega} = 4\lambda^\chi \omega^3 + 2\omega \left[\mu_\chi^2 + \left(2\lambda_1^{\chi\eta} + 2\lambda_1^{\chi\phi} \right) v^2 \right] - 2\mu_1 v = 0, \\
\frac{\partial V_{\text{tri}}}{\partial v} = 2v \left[2\omega^2 \left(\lambda_1^{\chi\eta} + \lambda_1^{\chi\phi} \right) + 2 \left(\mu_\eta^2 + \mu_{\phi'}^2 \right) \right. \\
\left. + 2 \left(\lambda_1^1 + \lambda_1^2 + \lambda_1^3 + 4\lambda_1^{\phi\eta} + \lambda_1^{\eta\eta'} + \lambda_2^{\eta\eta'} \right. \right. \\
\left. \left. + \lambda_3^{\eta\eta'} + \lambda_4^{\eta\eta'} + \lambda_1^{\phi\phi'} + \lambda_2^{\phi\phi'} + \lambda_3^{\phi\phi'} \right. \right. \\
\left. \left. + \lambda_4^{\phi\phi'} + 2\lambda^\phi + 2\lambda^\eta \right) v^2 - 2\mu_1 \omega \right] = 0.
\end{aligned} \tag{A.11}$$

This system has a solution as follows:

$$\begin{aligned}
u = u' = v' = v = \pm \frac{\sqrt{\omega \left(\mu_\chi^2 + \lambda^\chi \omega^2 \right)}}{\sqrt{\mu_1 - 2\omega \left(\lambda_1^{\chi\eta} + \lambda_1^{\chi\phi} \right)}}, \\
\omega = \frac{\alpha \mu_1}{2(\alpha^2 - \beta \lambda^\chi)} - \frac{\Omega}{3 \times 2^{2/3} (\alpha^2 - \beta \lambda^\chi) (\Gamma + \sqrt{\Gamma^2 + 4\Omega^3})^{1/3}} \\
+ \frac{(\Gamma + \sqrt{\Gamma^2 + 4\Omega^3})^{1/3}}{6 \times 2^{1/3} (\alpha^2 - \beta \lambda^\chi)},
\end{aligned} \tag{A.12}$$

where

$$\begin{aligned}
\Gamma &= 54\alpha\beta\mu_1 (\lambda^x \mu_1^2 + \alpha^2 \mu_x^2 - \beta\lambda^x \mu_x^2) \\
&\quad - 108\lambda^x \mu_1 \beta \gamma (\alpha^2 - \lambda^x \beta), \\
\Omega &= 6(\alpha^2 - \beta\lambda^x) (2\alpha\gamma + \mu_1^2 - \beta\mu_x^2) - 9\alpha^2 \mu_1^2, \\
\alpha &= \lambda_1^{x\eta} + \lambda_1^{x\phi}, \\
\beta &= \lambda_1^1 + \lambda_1^2 + \lambda_1^3 + 4\lambda_1^{\phi\eta} + \lambda^{\phi\phi'} + \lambda^{\eta\eta'} + 2(\lambda^\eta + \lambda^\phi), \\
\lambda^{\phi\phi'} &= \lambda_1^{\phi\phi'} + \lambda_2^{\phi\phi'} + \lambda_3^{\phi\phi'} + \lambda_4^{\phi\phi'}, \\
\lambda^{\eta\eta'} &= \lambda_1^{\eta\eta'} + \lambda_2^{\eta\eta'} + \lambda_3^{\eta\eta'} + \lambda_4^{\eta\eta'}.
\end{aligned} \tag{A.13}$$

Considering the potentials V_{sex} and $V_{\text{tri-sex}}$, we impose that

$$\begin{aligned}
\lambda_1^* &= \lambda_1, & \lambda_2^* &= \lambda_2, & \nu_1^* &= \nu_1, & \nu_2^* &= \nu_2, \\
\Lambda_1^* &= \Lambda_1, & \Lambda_2^* &= \Lambda_2, & \nu^* &= \nu, & \nu'^* &= \nu', \\
u^* &= u, & u'^* &= u', & \nu_\chi^* &= \nu_\chi, & \nu_\rho^* &= \nu_\rho,
\end{aligned} \tag{A.14}$$

and we obtain a system of equations of the potential minimization for antisextets:

$$\begin{aligned}
\frac{\partial V_1}{\partial \lambda_1} &= 2 \left\{ \lambda_2 \left[\lambda_1^{xs} \omega^2 + \mu_s^2 + (\lambda_1^{\eta s} + \lambda_2^{\eta s} + \lambda_3^{\eta s}) u^2 \right. \right. \\
&\quad + (\lambda_1^{\eta' s} + \lambda_2^{\eta' s} + \lambda_3^{\eta' s}) u'^2 + (\lambda_2' + \lambda_4') uu' \\
&\quad + \lambda_1^{\phi s} v^2 + \lambda_1^{\phi' s} v'^2 + \lambda_1' \nu \nu' \\
&\quad + 2(3\lambda_1^s + \lambda_2^s + \lambda_3^s + 4\lambda_4^s) \nu_1 \nu_2 + 4\lambda_4^s \Lambda_1 \Lambda_2 \left. \right] \\
&\quad + 2\Lambda_2 (\lambda_1^s - \lambda_2^s + \lambda_3^s) \nu_1 \nu_2 + 2\Lambda_1 (\lambda_1^s + \lambda_2^s) \nu_2^2 \\
&\quad + 2\lambda_1 \left[\lambda_6^s \Lambda_2^2 + \lambda_2^2 (2\lambda_1^s + \lambda_3^s + 2\lambda_4^s + \lambda_6^s) \right. \\
&\quad \left. + (\lambda_1^s - \lambda_2^s + \lambda_3^s + 2\lambda_6^s) \nu_2^2 \right] \left. \right\} = 0,
\end{aligned}$$

$$\begin{aligned}
\frac{\partial V_1}{\partial \lambda_2} &= 2 \left\{ \lambda_1 \left[\lambda_1^{xs} \omega^2 + \mu_s^2 + (\lambda_1^{\eta s} + \lambda_2^{\eta s} + \lambda_3^{\eta s}) u^2 \right. \right. \\
&\quad + (\lambda_1^{\eta' s} + \lambda_2^{\eta' s} + \lambda_3^{\eta' s}) u'^2 + (\lambda_2' + \lambda_4') uu' \\
&\quad + \lambda_1^{\phi s} v^2 + \lambda_1^{\phi' s} v'^2 + \lambda_1' \nu \nu' \\
&\quad + 2(3\lambda_1^s + \lambda_2^s + \lambda_3^s + 4\lambda_4^s) \nu_1 \nu_2 \\
&\quad + 4\lambda_4^s \Lambda_1 \Lambda_2 \left. \right] + 2\Lambda_1 (\lambda_1^s - \lambda_2^s + \lambda_3^s) \nu_1 \nu_2 \\
&\quad + 2\Lambda_2 (\lambda_1^s + \lambda_2^s) \nu_1^2 \\
&\quad + 2\lambda_2 \left[\lambda_6^s \Lambda_1^2 + \lambda_1^2 (2\lambda_1^s + \lambda_3^s + 2\lambda_4^s + \lambda_6^s) \right. \\
&\quad \left. + (\lambda_1^s - \lambda_2^s + \lambda_3^s + 2\lambda_6^s) \nu_1^2 \right] \left. \right\} = 0,
\end{aligned}$$

$$\begin{aligned}
\frac{\partial V_1}{\partial \nu_1} &= 2 \left\{ \nu_2 \left[(2\lambda_1^{xs} + \lambda_2^{xs} + \lambda_3^{xs}) \omega^2 + 2\mu_s^2 \right. \right. \\
&\quad + (2\lambda_1^{\eta s} + \lambda_2^{\eta s} + \lambda_3^{\eta s}) u^2 + (2\lambda_2' + \lambda_4') uu' \\
&\quad + (2\lambda_1^{\eta' s} + \lambda_2^{\eta' s} + \lambda_3^{\eta' s}) u'^2 + 2\lambda_1^{\phi s} v^2 + 2\lambda_1' \nu \nu' \\
&\quad + 2\lambda_1^{\phi' s} v'^2 + 2(\lambda_1 \Lambda_2 + \lambda_2 \Lambda_1) (\lambda_1^s - \lambda_2^s + \lambda_3^s) \\
&\quad + 2(\lambda_1 \lambda_2 + \Lambda_1 \Lambda_2) (3\lambda_1^s + \lambda_2^s + \lambda_3^s + 4\lambda_4^s) \left. \right] \\
&\quad + 2 \left[2\lambda_2 \Lambda_2 (\lambda_1^s + \lambda_2^s) + (\lambda_2^2 + \Lambda_2^2) \right. \\
&\quad \left. \times (\lambda_1^s - \lambda_2^s + \lambda_3^s + 2\lambda_6^s) \right] \nu_1 \\
&\quad + 4(2\lambda_1^s + \lambda_3^s + 4\lambda_4^s + 2\lambda_6^s) \nu_1 \nu_2^2 \left. \right\} = 0,
\end{aligned}$$

$$\begin{aligned}
\frac{\partial V_1}{\partial \nu_2} &= 2 \left\{ \nu_1 \left[(2\lambda_1^{xs} + \lambda_2^{xs} + \lambda_3^{xs}) \omega^2 + 2\mu_s^2 \right. \right. \\
&\quad + (2\lambda_1^{\eta s} + \lambda_2^{\eta s} + \lambda_3^{\eta s}) u^2 + (2\lambda_2' + \lambda_4') uu' \\
&\quad + (2\lambda_1^{\eta' s} + \lambda_2^{\eta' s} + \lambda_3^{\eta' s}) u'^2 + 2\lambda_1^{\phi s} v^2 + 2\lambda_1' \nu \nu' \\
&\quad + 2\lambda_1^{\phi' s} v'^2 + 2(\lambda_1 \Lambda_2 + \lambda_2 \Lambda_1) (\lambda_1^s - \lambda_2^s + \lambda_3^s) \\
&\quad + 2(\lambda_1 \lambda_2 + \Lambda_1 \Lambda_2) (3\lambda_1^s + \lambda_2^s + \lambda_3^s + 4\lambda_4^s) \left. \right] \\
&\quad + 2 \left[2\lambda_1 \Lambda_1 (\lambda_1^s + \lambda_2^s) + (\lambda_1^2 + \Lambda_1^2) \right. \\
&\quad \left. \times (\lambda_1^s - \lambda_2^s + \lambda_3^s + 2\lambda_6^s) \right] \nu_2 \\
&\quad + 4(2\lambda_1^s + \lambda_3^s + 4\lambda_4^s + 2\lambda_6^s) \nu_2 \nu_1^2 \left. \right\} = 0,
\end{aligned}$$

$$\begin{aligned}
\frac{\partial V_1}{\partial \Lambda_1} &= 2 \left\{ \Lambda_2 \left[(\lambda_1^{xs} + \lambda_2^{xs} + \lambda_3^{xs}) \omega^2 + \mu_s^2 + \lambda_1^{\eta s} u^2 \right. \right. \\
&\quad + \lambda_2' uu' + \lambda_1^{\eta' s} u'^2 + \lambda_1' \nu \nu' + \lambda_1^{\phi s} v^2 + \lambda_1^{\phi' s} v'^2 \\
&\quad + 4\lambda_4^s \lambda_1 \lambda_2 + 2(3\lambda_1^s + \lambda_2^s + \lambda_3^s + 4\lambda_4^s) \nu_1 \nu_2 \left. \right] \\
&\quad + 2\lambda_2 (\lambda_1^s - \lambda_2^s + \lambda_3^s) \nu_1 \nu_2 + 2\lambda_1 (\lambda_1^s + \lambda_2^s) \nu_2^2 \\
&\quad + 2\Lambda_1 \left[\lambda_6^s \Lambda_2^2 + \Lambda_2^2 (2\lambda_1^s + \lambda_3^s + 2\lambda_4^s + \lambda_6^s) \right. \\
&\quad \left. + (\lambda_1^s - \lambda_2^s + \lambda_3^s + 2\lambda_6^s) \nu_2^2 \right] \left. \right\} = 0,
\end{aligned}$$

$$\begin{aligned}
\frac{\partial V_1}{\partial \Lambda_2} &= 2 \left\{ \Lambda_1 \left[(\lambda_1^{xs} + \lambda_2^{xs} + \lambda_3^{xs}) \omega^2 + \mu_s^2 + \lambda_1^{\eta s} u^2 \right. \right. \\
&\quad + \lambda_2' uu' + \lambda_1^{\eta' s} u'^2 + \lambda_1' \nu \nu' + \lambda_1^{\phi s} v^2 + \lambda_1^{\phi' s} v'^2 \\
&\quad + 4\lambda_4^s \lambda_1 \lambda_2 + 2(3\lambda_1^s + \lambda_2^s + \lambda_3^s + 4\lambda_4^s) \nu_1 \nu_2 \left. \right] \\
&\quad + 2\lambda_1 (\lambda_1^s - \lambda_2^s + \lambda_3^s) \nu_1 \nu_2 + 2\lambda_2 (\lambda_1^s + \lambda_2^s) \nu_1^2
\end{aligned}$$

$$+ 2\Lambda_2 \left[\lambda_6^s \lambda_1^2 + \Lambda_1^2 (2\lambda_1^s + \lambda_3^s + 2\lambda_4^s + \lambda_6^s) + (\lambda_1^s - \lambda_2^s + \lambda_3^s + 2\lambda_6^s) v_1^2 \right] \Big\} = 0, \quad (\text{A.15})$$

where V_1 is a sum of V_{sext} and $V_{\text{tri-sext}}$:

$$V_1 = V_{\text{sext}} + V_{\text{tri-sext}} \quad (\text{A.16})$$

It is easily shown that (A.15) takes the same form in couples. This system of equations yields the following relations:

$$\lambda_1 = \kappa \lambda_2, \quad v_1 = \kappa v_2, \quad \Lambda_1 = \kappa \Lambda_2, \quad (\text{A.17})$$

where κ is a constant. It means that there are several alignments for VEVs. In this work, to have the desirable results, we have imposed the two directions for breaking $S_4 \rightarrow D_4$ and $S_4 \rightarrow K_4$ as mentioned, in which $\kappa = 1$ and $\kappa \neq 1$ but approximates to the unit. In the case that $\kappa = 1$ or $\lambda_1 = \lambda_2 = \lambda_s$, $v_1 = v_2 = v_s$, and $\Lambda_1 = \Lambda_2 = \Lambda_s$, the system of (A.15) reduces to system for minimal potential condition consisting of three equations as follows:

$$\begin{aligned} & \lambda_s \left[A_\omega + \mu_s^2 + 2A_s \Lambda_s^2 + 2(A_s + B_s) \lambda_s^2 + A_v \right. \\ & \quad \left. + 4(A_s + B_s) v_s^2 \right] + 2B_s \Lambda_s v_s^2 = 0, \\ & 2(A_\omega + B_\omega) + 2\mu_s^2 + A_v + A'_v + 4B_s \lambda_s \Lambda_s \\ & \quad + 4(A_s + B_s) (\lambda_s^2 + v_s^2 + \Lambda_s^2) = 0, \\ & \Lambda_s \left[A_\omega + B_\omega + \mu_s^2 + 2A_s \lambda_s^2 + 2(A_s + B_s) \Lambda_s^2 \right. \\ & \quad \left. + A'_v + 4(A_s + B_s) v_s^2 \right] + 2B_s \lambda_s v_s^2 = 0, \end{aligned} \quad (\text{A.18})$$

where

$$\begin{aligned} A_\omega &= \lambda_1^{X_s} \omega^2, & B_\omega &= (\lambda_2^{X_s} + \lambda_3^{X_s}) \omega^2, \\ A_s &= 2\lambda_4^s + \lambda_6^s, & B_s &= 2\lambda_1^s + \lambda_3^s, \\ A_v &= (\lambda'_1 + \lambda'_2 + \lambda'_4 + \lambda_1^{\phi_s} + \lambda_1^{\phi'_s} + \lambda_1^{\eta_s} + \lambda_2^{\eta_s} \\ & \quad + \lambda_3^{\eta_s} + \lambda_1^{\eta'_s} + \lambda_2^{\eta'_s} + \lambda_3^{\eta'_s}) v^2, \\ A'_v &= (\lambda'_1 + \lambda'_2 + \lambda_1^{\phi_s} + \lambda_1^{\phi'_s} + \lambda_1^{\eta_s} + \lambda_1^{\eta'_s}) v^2. \end{aligned} \quad (\text{A.19})$$

The system of (A.18) always has the solution $(\lambda_s, v_s, \Lambda_s)$ as expected, even though it is complicated. It is also noted that the above alignment is only one of the solutions to be imposed to have the desirable results.

B. S_4 Group and Clebsch-Gordan Coefficients

S_4 is the permutation group of four objects, which is also the symmetry group of a cube. It has 24 elements divided into 5 conjugacy classes, with $\underline{1}$, $\underline{1}'$, $\underline{2}$, $\underline{3}$, and $\underline{3}'$ as its 5 irreducible representations. Any element of S_4 can be formed

by multiplication of the generators S and T obeying the relations $S^4 = T^3 = 1$, $ST^2S = T$. Without loss of generality, we could choose $S = (1234)$, $T = (123)$ where the cycle (1234) denotes the permutation $(1, 2, 3, 4) \rightarrow (2, 3, 4, 1)$, and (123) means $(1, 2, 3, 4) \rightarrow (2, 3, 1, 4)$. The conjugacy classes generated from S and T are

$$\begin{aligned} C_1 &: 1, \\ C_2 &: (12)(34) = TS^2T^2, \quad (13)(24) = S^2, \\ & \quad (14)(23) = T^2S^2T, \\ C_3 &: (123) = T, \quad (132) = T^2, \quad (124) = T^2S^2, \\ & \quad (142) = S^2T, \quad (134) = S^2TS^2, \quad (143) = STS, \\ & \quad (234) = S^2T^2, \quad (243) = TS^2, \\ C_4 &: (1234) = S, \quad (1243) = T^2ST, \quad (1324) = ST, \\ & \quad (1342) = TS, \quad (1423) = TST^2, \quad (1432) = S^3, \\ C_5 &: (12) = STS^2, \quad (13) = TSTS^2, \quad (14) = ST^2, \\ & \quad (23) = S^2TS, \quad (24) = TST, \quad (34) = T^2S. \end{aligned} \quad (\text{B.1})$$

The character table of S_4 is given as shown in Table 1, where n is the order of class and h is the order of elements within each class. Let us note that $C_{1,2,3}$ are even permutations, while $C_{4,5}$ are odd permutations. The two three-dimensional representations differ only in the signs of their C_4 and C_5 matrices. Similarly, the two one-dimensional representations behave the same.

We will work on a basis where $\underline{3}$ and $\underline{3}'$ are real representations whereas $\underline{2}$ is complex. One possible choice of generators is given as follows:

$$\begin{aligned} \underline{1} &: S = 1, \quad T = 1, \\ \underline{1}' &: S = -1, \quad T = 1, \\ \underline{2} &: S = \begin{pmatrix} 0 & 1 \\ 1 & 0 \end{pmatrix}, \quad T = \begin{pmatrix} \omega & 0 \\ 0 & \omega^2 \end{pmatrix}, \\ \underline{3} &: S = \begin{pmatrix} -1 & 0 & 0 \\ 0 & 0 & -1 \\ 0 & 1 & 0 \end{pmatrix}, \quad T = \begin{pmatrix} 0 & 0 & 1 \\ 1 & 0 & 0 \\ 0 & 1 & 0 \end{pmatrix}, \\ \underline{3}' &: S = -\begin{pmatrix} -1 & 0 & 0 \\ 0 & 0 & -1 \\ 0 & 1 & 0 \end{pmatrix}, \quad T = \begin{pmatrix} 0 & 0 & 1 \\ 1 & 0 & 0 \\ 0 & 1 & 0 \end{pmatrix}, \end{aligned} \quad (\text{B.2})$$

where $\omega = e^{2\pi i/3} = -1/2 + i\sqrt{3}/2$ is the cube root of unity. Using them we calculate the Clebsch-Gordan coefficients for all the tensor products as given below.

First, let us put $\underline{3}(1, 2, 3)$ which means some $\underline{3}$ multiplet such as $x = (x_1, x_2, x_3) \sim \underline{3}$ or $y = (y_1, y_2, y_3) \sim \underline{3}$, and similarly for the other representations. Moreover, the numbered multiplets such as (\dots, ij, \dots) mean $(\dots, x_i y_j, \dots)$ where x_i and y_j are the multiplet components of different

TABLE 1

Class	n	h	χ_1	χ_1'	χ_2	χ_3	χ_3'
C_1	1	1	1	1	2	3	3
C_2	3	2	1	1	2	-1	-1
C_3	8	3	1	1	-1	0	0
C_4	6	4	1	-1	0	-1	1
C_5	6	2	1	-1	0	1	-1

representations x and y , respectively. In the following the components of representations in l.h.s will be omitted and should be understood, but they always exist in order in the components of decompositions in r.h.s.:

$$\begin{aligned}
\underline{1} \otimes \underline{1} &= \underline{1} (11), & \underline{1}' \otimes \underline{1}' &= \underline{1} (11), & \underline{1} \otimes \underline{1}' &= \underline{1}' (11), \\
\underline{1} \otimes \underline{2} &= \underline{2} (11, 12), & \underline{1}' \otimes \underline{2} &= \underline{2} (11, -12), \\
\underline{1} \otimes \underline{3} &= \underline{3} (11, 12, 13), & \underline{1}' \otimes \underline{3} &= \underline{3}' (11, 12, 13), \\
\underline{1} \otimes \underline{3}' &= \underline{3}' (11, 12, 13), & \underline{1}' \otimes \underline{3}' &= \underline{3} (11, 12, 13), \\
\underline{2} \otimes \underline{2} &= \underline{1} (12 + 21) \oplus \underline{1}' (12 - 21) \oplus \underline{2} (22, 11), \\
\underline{2} \otimes \underline{3} &= \underline{3} \left((1+2) 1, \omega (1+\omega) 2, \omega^2 (1+\omega^2) 3 \right) \\
&\oplus \underline{3}' \left((1-2) 1, \omega (1-\omega) 2, \omega^2 (1-\omega^2) 3 \right), \\
\underline{2} \otimes \underline{3}' &= \underline{3}' \left((1+2) 1, \omega (1+\omega) 2, \omega^2 (1+\omega^2) 3 \right) \\
&\oplus \underline{3} \left((1-2) 1, \omega (1-\omega) 2, \omega^2 (1-\omega^2) 3 \right), \\
\underline{3} \otimes \underline{3} &= \underline{1} (11 + 22 + 33) \\
&\oplus \underline{2} (11 + \omega^2 22 + \omega 33, 11 + \omega 22 + \omega^2 33) \\
&\oplus \underline{3}_s (23 + 32, 31 + 13, 12 + 21) \\
&\oplus \underline{3}'_a (23 - 32, 31 - 13, 12 - 21), \\
\underline{3}' \otimes \underline{3}' &= \underline{1} (11 + 22 + 33) \\
&\oplus \underline{2} (11 + \omega^2 22 + \omega 33, 11 + \omega 22 + \omega^2 33) \\
&\oplus \underline{3}_s (23 + 32, 31 + 13, 12 + 21) \\
&\oplus \underline{3}'_a (23 - 32, 31 - 13, 12 - 21), \\
\underline{3} \otimes \underline{3}' &= \underline{1}' (11 + 22 + 33) \\
&\oplus \underline{2} (11 + \omega^2 22 + \omega 33, -11 - \omega 22 - \omega^2 33) \\
&\oplus \underline{3}'_s (23 + 32, 31 + 13, 12 + 21) \\
&\oplus \underline{3}_a (23 - 32, 31 - 13, 12 - 21),
\end{aligned} \tag{B.3}$$

where the subscripts s and a , respectively, refer to their symmetric and antisymmetric product combinations as explicitly pointed out. We also notice that many group multiplication

TABLE 2

particles	L	P_l
$N_R, u, d, \phi_1^+, \phi_1'^+, \phi_2^0, \phi_2'^0, \eta_1^0, \eta_1'^0, \eta_2^-, \eta_2'^-, \chi_3^0, \sigma_{33}^0, s_{33}^0$	0	1
$\nu_L, l, U, D^*, \phi_3^+, \phi_3'^+, \eta_3^0, \eta_3'^0, \chi_1^{0*}, \chi_2^+, \sigma_{13}^0, \sigma_{23}^+, s_{13}^0, s_{23}^+$	-1	-1
$\sigma_{11}^0, \sigma_{12}^+, \sigma_{22}^+, s_{11}^0, s_{12}^+, s_{22}^+$	-2	1

rules above have similar forms as those of S_3 and A_4 groups [14, 112].

In the text we usually use the following notations, for example, $(xy')_{\underline{3}} = [xy']_{\underline{3}} \equiv (x_2 y'_3 - x_3 y'_2, x_3 y'_1 - x_1 y'_3, x_1 y'_2 - x_2 y'_1)$ which is the Clebsch-Gordan coefficients of $\underline{3}_a$ in the decomposition of $\underline{3} \otimes \underline{3}'$, whereas mentioned $x = (x_1, x_2, x_3) \sim \underline{3}$ and $y' = (y'_1, y'_2, y'_3) \sim \underline{3}'$.

The rules to conjugate the representations $\underline{1}, \underline{1}', \underline{2}, \underline{3}$, and $\underline{3}'$ are given by

$$\begin{aligned}
\underline{2}^* (1^*, 2^*) &= \underline{2} (2^*, 1^*), & \underline{1}^* (1^*) &= \underline{1} (1^*), \\
\underline{1}'^* (1^*) &= \underline{1}' (1^*), \\
\underline{3}^* (1^*, 2^*, 3^*) &= \underline{3} (1^*, 2^*, 3^*), \\
\underline{3}'^* (1^*, 2^*, 3^*) &= \underline{3}' (1^*, 2^*, 3^*),
\end{aligned} \tag{B.4}$$

where, for example, $\underline{2}^* (1^*, 2^*)$ denotes some $\underline{2}^*$ multiplet of the form $(x_1^*, x_2^*) \sim \underline{2}^*$.

C. The Numbers

In Table 2 we will explicitly point out the lepton number (L) and lepton parity (P_l) of the model particles (notice that the family indices are suppressed).

Conflict of Interests

The authors declare that there is no conflict of interests regarding the publication of this paper.

Acknowledgment

This research is funded by the Vietnam National Foundation for Science and Technology Development (NAFOSTED) under Grant no. 103.01-2011.63.

References

- [1] Super-Kamiokande Collaboration, Y. Fukuda, T. Hayakawa et al., "Evidence for oscillation of atmospheric neutrinos," *Physical Review Letters*, vol. 81, pp. 1562–1567, 1998.
- [2] Super-Kamiokande Collaboration, S. Fukuda, Y. Fukuda et al., "Solar 8B and hep neutrino measurements from 1258 days of Super-Kamiokande data," *Physical Review Letters*, vol. 86, no. 25, pp. 5651–5655, 2001.
- [3] S. Fukuda, Y. Fukuda, M. Ishitsuka et al., "Constraints on neutrino oscillations using 1258 days of Super-Kamiokande solar neutrino data," *Physical Review Letters*, vol. 86, no. 25, pp. 5656–5660, 2001.

- [4] S. Fukuda, Y. Fukuda, M. Ishitsuka et al., “Determination of solar neutrino oscillation parameters using 1496 days of Super-Kamiokande-I data,” *Physics Letters B*, vol. 539, pp. 179–187, 2002.
- [5] Super-Kamiokande Collaboration, Y. Ashie, J. Hosaka et al., “Evidence for an oscillatory signature in atmospheric neutrino oscillation,” *Physical Review Letters*, vol. 93, Article ID 101801, 2004.
- [6] Super-Kamiokande Collaboration, Y. Ashie, J. Hosaka et al., “A measurement of atmospheric neutrino oscillation parameters by Super-Kamiokande I,” *Physical Review D*, vol. 71, Article ID 112005, 35 pages, 2005.
- [7] J. Beringer, J.-F. Arguin, R. M. Barnett et al., “Review of particle physics,” *Physical Review D*, vol. 86, no. 1, Article ID 010001, 1528 pages, 2012.
- [8] T. Schwetz, M. Tórtola, and J. W. F. Valle, “Where we are on θ_{13} : addendum to ‘global neutrino data and recent reactor fluxes: status of three-flavor oscillation parameters,’” *New Journal of Physics*, vol. 13, Article ID 109401, 2011.
- [9] K. Abe, N. Abgrall, Y. Ajima et al., “Indication of electron neutrino appearance from an accelerator-produced off-axis muon neutrino beam,” *Physical Review Letters*, vol. 107, Article ID 041801, 8 pages, 2011.
- [10] P. Adamson, D. J. Auty, D. S. Ayres et al., “Improved search for muon-neutrino to electron-neutrino oscillations in MINOS,” *Physics Letters B*, vol. 107, no. 18, Article ID 181802, 2011.
- [11] G. L. Fogli, E. Lisi, A. Marrone, A. Palazzo, and A. M. Rotunno, “Evidence of $\theta_{13} > 0$ from global neutrino data analysis,” *Physical Review D*, vol. 84, no. 5, Article ID 053007, 2011.
- [12] N. Cabibbo, “Unitary symmetry and leptonic decays,” *Physical Review Letters*, vol. 10, no. 12, pp. 531–533, 1963.
- [13] M. Kobayashi and T. Maskawa, “CP-violation in the renormalizable theory of weak interaction,” *Progress of Theoretical Physics*, vol. 49, pp. 652–657, 1973.
- [14] E. Ma and G. Rajasekaran, “Softly broken A_4 symmetry for nearly degenerate neutrino masses,” *Physical Review D*, vol. 64, no. 11, Article ID 113012, 2001.
- [15] K. S. Babu, E. Ma, and J. W. F. Valle, “Underlying A_4 symmetry for the neutrino mass matrix and the quark mixing matrix,” *Physics Letters B*, vol. 552, no. 3-4, pp. 207–213, 2003.
- [16] G. Altarelli and F. Feruglio, “Tri-bimaximal neutrino mixing, A_4 and the modular symmetry,” *Nuclear Physics B*, vol. 741, no. 1-2, pp. 215–235, 2006.
- [17] E. Ma, “Tribimaximal neutrino mixing from a supersymmetric model with A_4 family symmetry,” *Physical Review D*, vol. 73, no. 5, Article ID 057304, 2006.
- [18] X.-G. He, Y.-Y. Keum, and R. R. Volkas, “ A_4 flavour symmetry breaking scheme for understanding quark and neutrino mixing angles,” *Journal of High Energy Physics*, vol. 2006, no. 4, article 039, 2006.
- [19] S. Morisi, M. Picariello, and E. Torrente-Lujan, “Model for fermion masses and lepton mixing in $SO(10) \times A_4$,” *Physical Review D*, vol. 75, no. 7, Article ID 075015, 2007.
- [20] C. S. Lam, “Symmetry of lepton mixing,” *Physics Letters B*, vol. 656, no. 4-5, pp. 193–198, 2007.
- [21] F. Bazzocchi, S. Kaneko, and S. Morisi, “A SUSY A_4 model for fermion masses and mixings,” *Journal of High Energy Physics*, vol. 2008, no. 3, article 063, 2008.
- [22] F. Bazzocchi, M. Frigerio, and S. Morisi, “Fermion masses and mixing in models with $SO(10) \times A_4$ symmetry,” *Physical Review D*, vol. 78, no. 11, Article ID 116018, 2008.
- [23] G. Altarelli, F. Feruglio, and C. Hagedorn, “A SUSY $SU(5)$ grand unified model of tri-bimaximal mixing from A_4 ,” *Journal of High Energy Physics*, vol. 2008, no. 3, article 052, 2008.
- [24] M. Hirsch, S. Morisi, and J. W. F. Valle, “Tribimaximal neutrino mixing and neutrinoless double beta decay,” *Physical Review D*, vol. 78, no. 9, Article ID 093007, 2008.
- [25] E. Ma, “Dark scalar doublets and neutrino tribimaximal mixing from A_4 symmetry,” *Physics Letters B*, vol. 671, no. 3, pp. 366–368, 2009.
- [26] Y. Lin, “A predictive A_4 model, charged lepton hierarchy and tri-bimaximal sum rule,” *Nuclear Physics B*, vol. 813, no. 1-2, pp. 91–105, 2009.
- [27] Y. H. Ahn and C.-S. Chen, “Nonzero U_{e3} and TeV leptogenesis through A_4 symmetry breaking,” *Physical Review D*, vol. 81, no. 10, Article ID 105013, 2010.
- [28] J. Barry and W. Rodejohann, “Deviations from tribimaximal mixing due to the vacuum expectation value misalignment in A_4 models,” *Physical Review D*, vol. 81, Article ID 093002, 2010.
- [29] G.-J. Ding and D. Meloni, “A model for tri-bimaximal mixing from a completely broken A_4 ,” *Nuclear Physics B*, vol. 855, no. 1, pp. 21–45, 2012.
- [30] L. Wolfenstein, “Oscillations among three neutrino types and CP violation,” *Physical Review D*, vol. 18, no. 3, pp. 958–960, 1978.
- [31] S. Pakvasa and H. Sugawara, “Discrete symmetry and Cabibbo angle,” *Physics Letters B*, vol. 73, no. 1, pp. 61–64, 1978.
- [32] E. Derman and H.-S. Tsao, “ $[SU_2 \times U_1] \times S_n$ flavor dynamics and a bound on the number of flavors,” *Physical Review D*, vol. 20, no. 5, pp. 1207–1215, 1979.
- [33] Y. Yamanaka, H. Sugawara, and S. Pakvasa, “Permutation symmetries and the fermion mass matrix,” *Physical Review D*, vol. 25, no. 7, pp. 1895–1903, 1982.
- [34] K. Kang, J. E. Kim, and P. Ko, “A simple modification of the maximal mixing scenario for three light neutrinos,” *Zeitschrift für Physik C*, vol. 72, no. 4, pp. 671–675, 1996.
- [35] H. Fritzsch and Z.-Z. Xing, “Lepton mass hierarchy and neutrino oscillations,” *Physics Letters B*, vol. 372, no. 3-4, pp. 265–270, 1996.
- [36] K. Kang, S. K. Kang, J. E. Kim, and P. Ko, “Almost maximally broken permutation symmetry for neutrino mass matrix,” *Modern Physics Letters A*, vol. 12, no. 16, pp. 1175–1184, 1997.
- [37] M. Fukugita, M. Tanimoto, and T. Yanagida, “Atmospheric neutrino oscillation and a phenomenological lepton mass matrix,” *Physical Review D*, vol. 57, no. 7, pp. 4429–4432, 1998.
- [38] H. Fritzsch and Z.-Z. Xing, “Large leptonic flavour mixing and the mass spectrum of leptons,” *Physics Letters B*, vol. 440, no. 3-4, pp. 313–318, 1998.
- [39] Y. Koide, “Universal seesaw mass matrix model with an S_3 symmetry,” *Physical Review D*, vol. 60, no. 7, Article ID 077301, 4 pages, 1999.
- [40] H. Fritzsch and Z.-Z. Xing, “Maximal neutrino mixing and maximal CP violation,” *Physical Review D*, vol. 61, no. 7, Article ID 073016, 7 pages, 2000.
- [41] M. Tanimoto, “Large mixing angle MSW solution in S_3 flavor symmetry,” *Physics Letters B*, vol. 483, no. 4, pp. 417–424, 2000.
- [42] G. C. Branco and J. I. Silva-Marcos, “The symmetry behind extended flavour democracy and large leptonic mixing,” *Physics Letters B*, vol. 526, no. 1-2, pp. 104–110, 2002.
- [43] M. Fujii, K. Hamaguchi, and T. Yanagida, “Leptogenesis with almost degenerate Majorana neutrinos,” *Physical Review D*, vol. 65, no. 11, Article ID 115012, 2002.

- [44] J. Kubo, A. Mondragón, M. Mondragón, and E. Rodríguez-Jáuregui, “The flavor symmetry,” *Progress of Theoretical Physics*, vol. 109, no. 5, pp. 795–807, 2003.
- [45] J. Kubo, “Majorana phase in minimal S_3 invariant extension of the standard model,” *Physics Letters B*, vol. 578, no. 1-2, pp. 156–164, 2004.
- [46] P. F. Harrison and W. G. Scott, “Permutation symmetry, tribimaximal neutrino mixing and the S_3 group characters,” *Physics Letters B*, vol. 557, no. 1-2, pp. 76–86, 2003.
- [47] S. L. Chen, M. Frigerio, and E. Ma, “Large neutrino mixing and normal mass hierarchy: a discrete understanding,” *Physical Review D*, vol. 70, Article ID 073008, 2004.
- [48] H. Fritzsch and Z.-Z. Xing, “Democratic neutrino mixing reexamined,” *Physics Letters B*, vol. 598, no. 3-4, pp. 237–242, 2004.
- [49] W. Grimus and L. Lavoura, “ $S_3 \times \mathbb{Z}_2$ model for neutrino mass matrices,” *Journal of High Energy Physics*, vol. 2005, article 013, 2005.
- [50] R. N. Mohapatra, S. Nasri, and H.-B. Yu, “ S_3 symmetry and tribimaximal mixing,” *Physics Letters B*, vol. 639, no. 3-4, pp. 318–321, 2006.
- [51] R. Jora, S. Nasri, and J. Schechter, “An approach to permutation symmetry for the electroweak theory,” *International Journal of Modern Physics A*, vol. 21, no. 28-29, pp. 5875–5894, 2006.
- [52] J. E. Kim and J. C. Park, “Quantum numbers of heavy neutrinos, tri-bi-maximal mixing through double seesaw with permutation symmetry, and comment on $\theta_{\text{sol}} + \theta_c \approx \pi/4$,” *Journal of High Energy Physics*, vol. 2006, article 017, 2006.
- [53] Y. Koide, “ S_3 symmetry and neutrino masses and mixings,” *The European Physical Journal C*, vol. 50, no. 4, pp. 809–816, 2007.
- [54] A. Mondragón, M. Mondragón, and E. Peinado, “Lepton masses, mixings, and flavor-changing neutral currents in a minimal S_3 -invariant extension of the standard model,” *Physical Review D*, vol. 76, no. 7, Article ID 076003, 2007.
- [55] M. Picariello, “Neutrino CP violating parameters from nontrivial quark lepton correlation: a $S_3 \times$ GUT model,” *International Journal of Modern Physics A*, vol. 23, no. 27-28, pp. 4435–4448, 2008.
- [56] C.-Y. Chen and L. Wolfenstein, “Consequences of approximate S_3 symmetry of the neutrino mass matrix,” *Physical Review D*, vol. 77, no. 9, Article ID 093009, 2008.
- [57] R. Jora, J. Schechter, and M. N. Shahid, “Perturbed S_3 neutrinos,” *Physical Review D*, vol. 80, Article ID 093007, 2009.
- [58] D. A. Dicus, S.-F. Ge, and W. W. Repko, “Neutrino mixing with broken S_3 symmetry,” *Physical Review D*, vol. 82, no. 3, Article ID 033005, 2010.
- [59] Z.-Z. Xing, D. Yang, and S. Zhou, “Broken S_3 flavor symmetry of leptons and quarks: mass spectra and flavor mixing patterns,” *Physics Letters B*, vol. 690, no. 3, pp. 304–310, 2010.
- [60] R. Jora, J. Schechter, and M. N. Shahid, “Doubly perturbed S_3 neutrinos and the s_{13} mixing parameter,” *Physical Review D*, vol. 82, no. 5, Article ID 053006, 2010.
- [61] S. Dev, S. Gupta, and R. R. Gautam, “Broken S_3 symmetry in the neutrino mass matrix,” *Physics Letters B*, vol. 702, no. 1, pp. 28–33, 2011.
- [62] D. Meloni, S. Morisi, and E. Peinado, “Fritzsch neutrino mass matrix from S_3 symmetry,” *Journal of Physics G*, vol. 38, no. 1, Article ID 015003, 2011.
- [63] G. Bhattacharyya, P. Leser, and H. Päs, “Exotic Higgs boson decay modes as a harbinger of S_3 flavor symmetry,” *Physical Review D*, vol. 83, no. 1, Article ID 011701, 2011.
- [64] T. Kaneko and H. Sugawara, “Broken S_3 symmetry in flavor physics,” *Physics Letters B*, vol. 697, no. 4, pp. 329–332, 2011.
- [65] S. Zhou, “Relatively large θ_{13} and nearly maximal θ_{23} from the approximate S_3 symmetry of lepton mass matrices,” *Physics Letters B*, vol. 704, no. 4, pp. 291–295, 2011.
- [66] R. N. Mohapatra, M. K. Parida, and G. Rajasekaran, “High scale mixing unification and large neutrino mixing angles,” *Physical Review D*, vol. 69, no. 5, Article ID 053007, 2004.
- [67] C. Hagedorn, M. Lindner, and R. N. Mohapatra, “ S_4 flavor symmetry and fermion masses: towards a grand unified theory of flavor,” *Journal of High Energy Physics*, vol. 2006, no. 6, article 042, 2006.
- [68] E. Ma, “Neutrino mass matrix from S_4 symmetry,” *Physics Letters B*, vol. 632, no. 2-3, pp. 352–356, 2006.
- [69] H. Zhang, “Flavor $S_4 \otimes \mathbb{Z}_2$ symmetry and neutrino mixing,” *Physics Letters B*, vol. 655, no. 3-4, pp. 132–140, 2007.
- [70] Y. Koide, “ S_4 flavor symmetry embedded into SU(3) and lepton masses and mixing,” *Journal of High Energy Physics*, vol. 2007, no. 8, article 086, 2007.
- [71] H. Ishimori, Y. Shimizu, and M. Tanimoto, “ S_4 flavor symmetry of quarks and leptons in SU(5) GUT,” *Progress of Theoretical Physics*, vol. 121, no. 4, pp. 769–787, 2009.
- [72] F. Bazzocchi, L. Merlo, and S. Morisi, “Fermion masses and mixings in a S_4 based model,” *Nuclear Physics B*, vol. 816, no. 1-2, pp. 204–226, 2009.
- [73] F. Bazzocchi and S. Morisi, “ S_4 as a natural flavor symmetry for lepton mixing,” *Physical Review D*, vol. 80, no. 9, Article ID 096005, 2009.
- [74] G. Altarelli and F. Feruglio, “Discrete flavor symmetries and models of neutrino mixing,” *Reviews of Modern Physics*, vol. 82, no. 3, pp. 2701–2729, 2010.
- [75] G.-J. Ding, “Fermion masses and flavor mixings in a model with S_4 flavor symmetry,” *Nuclear Physics B*, vol. 827, no. 1-2, pp. 82–111, 2010.
- [76] Y. H. Ahn, S. K. Kang, C. S. Kim, and T. P. Nguyen, “A direct link between neutrinoless double beta decay and leptogenesis in a seesaw model with S_4 symmetry,” *Physical Review D*, vol. 82, no. 9, Article ID 093005, 2010.
- [77] H. Ishimori, Y. Shimizu, M. Tanimoto, and A. Watanabe, “Neutrino masses and mixing from S_4 flavor twisting,” *Physical Review D*, vol. 83, no. 3, Article ID 033004, 2011.
- [78] H. Ishimori and M. Tanimoto, “Slepton mass matrices $\mu \rightarrow e\gamma$ decay and EDM in SUSY S_4 flavor model,” *Progress of Theoretical Physics*, vol. 125, no. 4, pp. 653–675, 2011.
- [79] R.-Z. Yang and H. Zhang, “Minimal seesaw model with S_4 flavor symmetry,” *Physics Letters B*, vol. 700, no. 5, pp. 316–321, 2011.
- [80] S. Morisi and E. Peinado, “Admixture of quasi-Dirac and Majorana neutrinos with tri-bimaximal mixing,” *Physics Letters B*, vol. 701, no. 4, pp. 451–457, 2011.
- [81] T. Phong Nguyen and P. V. Dong, “Radiatively generated leptogenesis in S_4 flavor symmetry models,” *Advances in High Energy Physics*, vol. 2012, Article ID 254093, 21 pages, 2012.
- [82] L. Dorame, S. Morisi, E. Peinado, J. W. F. Valle, and A. D. Rojas, “A new neutrino mass sum rule from inverse seesaw,” *Physical Review D*, vol. 86, Article ID 056001, 2012.
- [83] D. Hernandez and A. Yu. Smirnov, “Lepton mixing and discrete symmetries,” *Physical Review D*, vol. 86, Article ID 053014, 2012.
- [84] Z. Zhao, “Understanding for flavor physics in the lepton sector,” *Physical Review D*, vol. 86, Article ID 096010, 2012.

- [85] R. Krishnan, P. F. Harrison, and W. G. Scott, “Simplest neutrino mixing from S_4 symmetry,” *Journal of High Energy Physics*, vol. 2013, no. 4, article 087, 2013.
- [86] R. Krishnan, “A model for large θ_{13} constructed using the eigenvectors of the S_4 rotation matrices,” *Journal of Physics: Conference Series*, vol. 447, Article ID 012043, 2013.
- [87] I. M. Varzielas and L. Lavoura, “Flavour models for TM_1 lepton mixing,” *Journal of Physics G*, vol. 40, no. 8, Article ID 085002, 2013.
- [88] W. Grimus, “Discrete symmetries, roots of unity, and lepton mixing,” *Journal of Physics G*, vol. 40, no. 7, Article ID 075008, 2013.
- [89] S. F. King and C. Luhn, “Neutrino mass and mixing with discrete symmetry,” *Reports on Progress in Physics*, vol. 76, no. 5, Article ID 056201, 2013.
- [90] R. G. Felipe, H. Serodio, and J. P. Silva, “Models with three Higgs doublets in the triplet representations of A_4 or S_4 ,” *Physical Review D*, vol. 87, Article ID 055010, 2013.
- [91] Y. Daikoku and H. Okada, “Phenomenology of S_4 flavor symmetric extra $U(1)$ model,” *Physical Review D*, vol. 88, no. 1, Article ID 015034, 27 pages, 2013.
- [92] F. Feruglio, C. Hagedorn, and R. Ziegler, “A realistic pattern of lepton mixing and masses from S_4 and CP,” *The European Physical Journal C*, vol. 74, article 2753, 2014.
- [93] C. Luhn, “Trimaximal TM_1 neutrino mixing in S_4 with spontaneous CP violation,” *Nuclear Physics B*, vol. 875, no. 1, pp. 80–100, 2013.
- [94] J. W. F. Valle and M. Singer, “Lepton-number violation with quasi-Dirac neutrinos,” *Physical Review D*, vol. 28, no. 3, pp. 540–545, 1983.
- [95] F. Pisano and V. Pleitez, “ $SU(3) \otimes U(1)$ model for electroweak interactions,” *Physical Review D*, vol. 46, no. 1, pp. 410–417, 1992.
- [96] P. H. Frampton, “Chiral dilepton model and the flavor question,” *Physical Review Letters*, vol. 69, no. 20, pp. 2889–2891, 1992.
- [97] R. Foot, O. F. Hernández, F. Pisano, and V. Pleitez, “Lepton masses in an $SU(3)_L \otimes U(1)_N$ gauge model,” *Physical Review D*, vol. 47, no. 9, pp. 4158–4161, 1993.
- [98] J. C. Montero, F. Pisano, and V. Pleitez, “Neutral currents and Glashow-Iliopoulos-Maiani mechanism in $SU(3)_L \otimes U(1)_N$ models for electroweak interactions,” *Physical Review D*, vol. 47, no. 7, pp. 2918–2929, 1993.
- [99] M. Singer, J. W. F. Valle, and J. Schechter, “Canonical neutral-current predictions from the weak-electromagnetic gauge group $SU(3) \times U(1)$,” *Physical Review D*, vol. 22, no. 3, pp. 738–743, 1980.
- [100] R. Foot, H. N. Long, and T. A. Tran, “ $SU(3)_L \otimes U(1)_N$ and $SU(4)_L \otimes U(1)_N$ gauge models with right-handed neutrinos,” *Physical Review D*, vol. 50, no. 1, pp. R34–R38, 1994.
- [101] J. C. Montero, F. Pisano, and V. Pleitez, “Neutral currents and Glashow-Iliopoulos-Maiani mechanism in $SU(3)_L \otimes U(1)_N$ models for electroweak interactions,” *Physical Review D*, vol. 47, no. 7, pp. 2918–2929, 1993.
- [102] H. N. Long, “ $SU(3)_L \otimes U(1)_N$ model for right-handed neutrino neutral currents,” *Physical Review D*, vol. 54, no. 7, pp. 4691–4693, 1996.
- [103] H. N. Long, “ $SU(3)_C \otimes SU(3)_L \otimes U(1)_N$ model with right-handed neutrinos,” *Physical Review D*, vol. 53, no. 1, pp. 437–445, 1996.
- [104] H. N. Long, “Scalar sector of the 3-3-1 model with three Higgs triplets,” *Modern Physics Letters A*, vol. 13, no. 23, pp. 1865–1873, 1998.
- [105] P. V. Dong and H. N. Long, “Neutrino masses and lepton flavor violation in the 3-3-1 model with right-handed neutrinos,” *Physical Review D*, vol. 77, no. 5, Article ID 057302, 2008.
- [106] W. A. Ponce, Y. Giraldo, and L. A. Sánchez, “Minimal scalar sector of 3-3-1 models without exotic electric charges,” *Physical Review D*, vol. 67, no. 7, Article ID 075001, 2003.
- [107] P. V. Dong, H. N. Long, D. T. Nhung, and D. V. Soa, “ $SU(3)_C \otimes SU(3)_L \otimes U(1)_X$ model with two Higgs triplets,” *Physical Review D*, vol. 73, no. 3, Article ID 035004, 2006.
- [108] P. V. Dong and H. N. Long, “The economical $SU(3)_C \otimes SU(3)_L \otimes U(1)_X$ model,” *Advances in High Energy Physics*, vol. 2008, Article ID 739492, 75 pages, 2008.
- [109] P. V. Dong, H. T. Hung, and H. N. Long, “Question of Peccei-Quinn symmetry and quark masses in the economical 3-3-1 model,” *Physical Review D*, vol. 86, no. 3, Article ID 033002, 13 pages, 2012.
- [110] P. V. Dong, L. T. Hue, H. N. Long, and D. V. Soa, “The 3-3-1 model with A_4 flavor symmetry,” *Physical Review D*, vol. 81, no. 5, Article ID 053004, 2010.
- [111] P. V. Dong, H. N. Long, C. H. Nam, and V. V. Vien, “ S_3 flavor symmetry in 3-3-1 models,” *Physical Review D*, vol. 85, no. 5, Article ID 053001, 2012.
- [112] P. V. Dong, H. N. Long, D. V. Soa, and V. V. Vien, “The 3-3-1 model with S_4 flavor symmetry,” *The European Physical Journal C*, vol. 71, no. 2, article 1544, 2011.
- [113] V. V. Vien and H. N. Long, “The D_4 flavor symmetry in 3-3-1 model with neutral leptons,” *International Journal of Modern Physics A*, vol. 28, no. 32, Article ID 1350159, 48 pages, 2013.
- [114] P. F. Harrison, D. H. Perkins, and W. G. Scott, “Tri-bimaximal mixing and the neutrino oscillation data,” *Physics Letters B*, vol. 530, no. 1–4, pp. 167–173, 2002.
- [115] Z.-Z. Xing, “Nearly tri-bimaximal neutrino mixing and CP violation,” *Physics Letters B*, vol. 533, no. 1–2, pp. 85–93, 2002.
- [116] X.-G. He and A. Zee, “Some simple mixing and mass matrices for neutrinos,” *Physics Letters B*, vol. 560, no. 1–2, pp. 87–90, 2003.
- [117] X.-G. He and A. Zee, “Neutrino masses with a “zero sum” condition: $m_{\nu 1} + m_{\nu 2} + m_{\nu 3} = 0$,” *Physical Review D*, vol. 68, no. 3, Article ID 037302, 2003.
- [118] D. Chang and H. N. Long, “Interesting radiative patterns of neutrino mass in an $SU(3)_C \otimes SU(3)_L \otimes U(1)_X$ model with right-handed neutrinos,” *Physical Review D*, vol. 73, no. 5, Article ID 053006, 2006.
- [119] K. Nakamura, K. Hagiwara, K. Hikasa et al., “Review of particle physics,” *Journal of Physics G*, vol. 37, Article ID 075021, 2010.
- [120] M. C. Gonzalez-Garcia, M. Maltoni, and J. Salvadò, “Updated global fit to three neutrino mixing: status of the hints of $\theta_{13} > 0$,” *Journal of High Energy Physics*, vol. 2010, no. 4, article 056, 2010.
- [121] P. V. Dong and H. N. Long, “ $U(1)_Q$ invariance and $SU(3)_C \otimes SU(3)_L \otimes U(1)_X$ models with β arbitrary,” *The European Physical Journal C*, vol. 42, no. 3, pp. 325–329, 2005.
- [122] P. V. Dong, V. T. N. Huyen, H. N. Long, and H. V. Thuy, “Gauge boson mixing in the 3-3-1 models with discrete symmetries,” *Advances in High Energy Physics*, vol. 2012, Article ID 715038, 18 pages, 2012.
- [123] D. V. Soa, P. V. Dong, T. T. Huong, and H. N. Long, “Bilepton contributions to the neutrinoless double beta decay in the economical 3-3-1 model,” *Journal of Experimental and Theoretical Physics*, vol. 108, no. 5, pp. 757–763, 2009.

- [124] J. C. Montero, C. A. D. S. Pires, and V. Pleitez, "Neutrinoless double beta decay with and without Majoron-like boson emission in a 3-3-1 model," *Physical Review D*, vol. 64, no. 9, Article ID 096001, 2001.
- [125] A. G. Dias, A. Doff, C. A. S. Pires, and P. S. Rodrigues da Silva, "Neutrino decay and neutrinoless double beta decay in a 3-3-1 model," *Physical Review D*, vol. 72, no. 3, Article ID 035006, 8 pages, 2005.

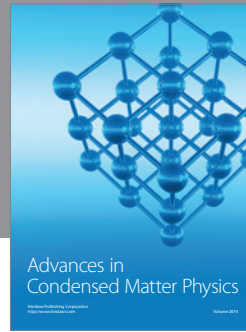
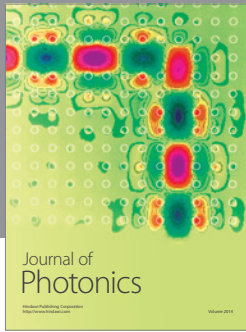
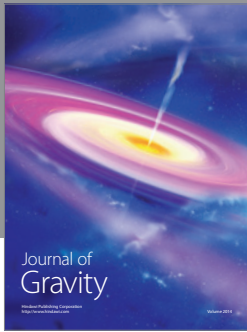

Hindawi

Submit your manuscripts at
<http://www.hindawi.com>

